

Investigation of the August 1, 2002, Collapse of Roadside Billboard during Erection in Snellville, GA

U.S. Department of Labor
Occupational Safety and Health Administration
Directorate of Construction

December 2002



REPORT

Investigation of the August 1, 2002, Collapse of Roadside Billboard During Erection in Snellyville, GA

Report prepared by
Mohammad Ayub, PE
Dinesh Shah, PE

REPORT

Background:

The Directorate of Construction, National OSHA Office, was requested to provide assistance in the investigation and causal determination of the August 1, 2002, collapse of a large roadside billboard in Snellville, GA. A structural engineer from the Office of Engineering, Directorate of Construction, National OSHA Office, accompanied by personnel from the Atlanta East OSTIA Area Office, visited the incident site on August 7, 2002.

Incident:

The incident occurred at about noon as a work crew was completing the electrical and other works to the billboard support framing, located at a shopping center at Route 124 and Dogwood Road, near Ronald Reagan Parkway, Snellville, GA, on August 1, 2002. The erection of the billboard framing was completed the previous day. The billboard collapse caused three fatalities and damaged several cars parked nearby.

Description of the Project:

The project, "D & L Interiors Billboard", consisted of fabrication and erection of structural steel framing to support two Tri Vision panel signs, on two opposite faces, each weighing approximately 5,400 pounds. The structural steel framing of the billboard was shown on the construction drawing # ED-2928 of July 9, 2002, bearing the signature of the professional engineer of record. See Figure 1 and 2 showing parts of the drawing. The framing was designed to be supported on a single column 42" diameter hollow structural tube. At the top of the column was a 12-foot long cantilever beam, a 30-inch diameter hollow structural tube. At the end of the cantilever beam, a 30-inch diameter stub pipe was placed. At the top of the stub pipe, another 40-foot long cantilever member, known as "torsion bar" was placed consisting of 30-inch diameter hollow structural tube. The torsion bar was placed at right angles to the cantilever beam. The actual signs were to be framed to the torsion bar. Observation of the failed structure indicated a number of variations between the "as designed" and "as built" framing. This is discussed later. The Thompson Engineering Group, LLC (TEG) of Athens, TN, designed the billboard framing and was the structural engineer of record. The Phoenix Structure and Services, Inc. of Athens, TN, was the structural steel fabricator; John J-mar Inc. was the steel erector; and Fowler Sign Co. was the sign erector. Trinity Outdoor of Buford, GA, was the owner and holder of the permit for the sign.

Collapse Description:

The structural steel framing (Figures 1 & 2), including walkway and billboard, was completed one day prior to the incident. Since the steel erection was completed, steel erectors were not present on the day of the incident. On the morning of August 1, 2002, a three men work crew engaged in electrical and sign works was performing finishing work on the newly erected sign.

The billboard signs and a portion of the structural framing consisting of the torsion bar and the stub pipe suddenly collapsed (Figures 4 & 5) shortly before noon, killing all three workers and crushing the cars parked below (Figure 6). Fortunately there were no pedestrians present and the cars were unoccupied at the time of the collapse.

During the field visit on August 7, 2002, it was observed that the failure occurred at the welded joint between the stub pipe and the 12-foot long cantilever beam. The cantilever beam and the column remained in place during the collapse (Figure 4). The failed joint involved a complete separation of the stub pipe and the cantilever beam (Figures 7 & 8). In addition to the failure at the welded joint, there was a tearing of the tubular section of the cantilever beam near the junction of the stub pipe (Figures 9 & 10).

A number of discrepancies were recorded between the “as designed” and “as built” structure:

- a) The wall thickness of the stub pipe was measured to be 7/16” instead of 5/8” as required by the design.
- b) The column consisted of two parts of hollow structural tubes of varying diameter; the bottom part was a larger hollow tube than the top part. The design called for one uniform cross section for the entire column height. The column, however, did not fail.
- c) The torsion bar consisted of two hollow structural sections of 5/8” and 1/2” thickness instead of one uniform section of 5/8” thickness. The splice of the two sections of the torsion bar was groove welded. The torsion bar fell intact with the stub pipe during the collapse.

Analysis:

This office conducted a structural analysis to determine the causal factors that may have contributed to the collapse of the billboard framing. The following assumptions were made:

1. Design loads and moments were taken from the original calculations generated by TEG for the billboard design.
2. The connections between the members were checked using Load and Resistance Factor Design (LRFD) method.
3. For strength design, the connection was checked using a usual load factor of 1.4 for dead load, and a strength reduction factor of 0.80.
4. For ultimate failure evaluation, the connection was checked using a load factor of 1.0 for dead load, and a strength reduction factor of 1.0.
5. Only gravity loads were considered. Wind was not considered to be a governing factor on the day of the incident.
6. The horizontal cantilever beam was checked at the T connection.
7. The yield strength of the material was considered to be 50,000 psi.

The structural framing design by TEG was based on a commercially available computer software

program RISA-3D, version 4.5. It was discovered that TEG did not perform necessary calculations to conform to the design requirement of the American Institute of Steel Construction's (AISC) Load and Resistance Factor Design Specification for Steel Hollow Structural Sections published on November 10, 2000. The specifications provide safeguards against different failure modes that are unique to the connection of hollow structural tubes. The specification requires, among other things, to check the chord wall plastification (local failure), which produces high local stresses and distortions in the vicinity of the joint due to bending in the wall of the chord.

The analysis indicated that the cantilever beam at the intersection of the stub pipe had an ultimate failure capacity of 8,511 inch kips, taking both the load factor and strength reduction factor of 1.0, against chord wall plastification. The selfweight and the billboard weight, however, imposed a force of 11,786 inch kips. Thus, the connection at the joint was overstressed by 35% beyond its ultimate capacity, leading to its failure. Considering a load factor of 1.4 for dead load, and a strength reduction factor of 0.80 for the usual strength design, the connection was overstressed by over 130 %. In addition, the lack of full penetration weld, as required by the design and construction document, between the cantilever beam and the stub pipe undermined the integrity of the connection and was an additional causal factor to the collapse. The failure generated a large hole on the cantilever beam (Figure 10) where the stub pipe had separated at the weld joint.

The flaws in the weld between the stub pipe and 12-foot long cantilever beam was evaluated and documented by the City of Snellville, GA. The evaluation was based on visual examination of the weld where the failure occurred. The report indicates that the subject weld joint was a partial penetration weld in lieu of full penetration, and was performed with very little weld joint preparation and subsequent weld penetration. Flame cutting was utilized without subsequent grinding of the faying surfaces of the pipe at joint, which led to the lack of fusion throughout the weld joint (Figures 10 to 12). It was further observed by the City of Snellville, GA, that the connections had some areas of fillet weld reinforcement with poor fit-up geometry. The City report concluded, "A substantial portion of the weld areas were observed to have lack of fusion between the weld and base material members as well as cold lap conditions."

Conclusions:

1. Two factors contributed to the billboard collapse, but it is difficult to determine which factor was predominant in causing the failure:
 - a. The structural design of the framing did not conform to the requirements of the American Institute of Steel Construction (AISC)'s Load and Resistance Factor Design Specification for Steel Hollow Structural Sections dated November 10, 2000. This is a recognized design code for hollow structural members in the steel industry. The requirement of chord wall plastification at the junction of the stub pipe and the cantilever beam was not met.
 - b. The weld at the junction of the stub pipe and the cantilever beam was not properly

performed. The contractor retained by the City of Snellville reported extensive flaws in the weld, based on a visual examination. The flaws included partial penetration weld instead of the full penetration weld, lack of fusion, poor weld joint penetration, etc.

2. The fabricator deviated from the approved plans in several ways, most notably in the reduced wall thickness of the stub pipe, a splice in the torsion bar, and the splice and change of section of the column.
3. Wind is not considered a causal factor in the collapse.

18" Interior catwalks not shown for clarity.

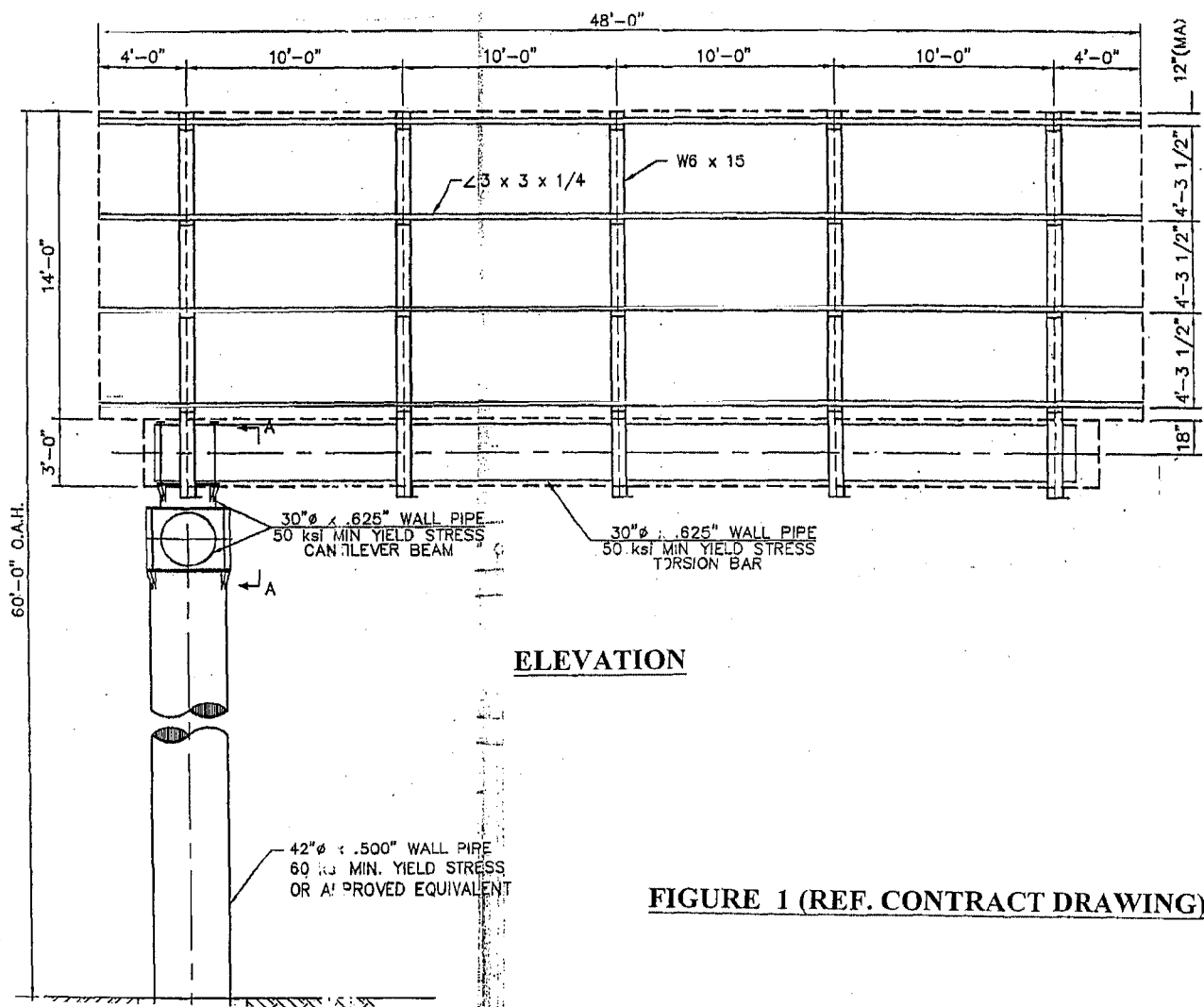
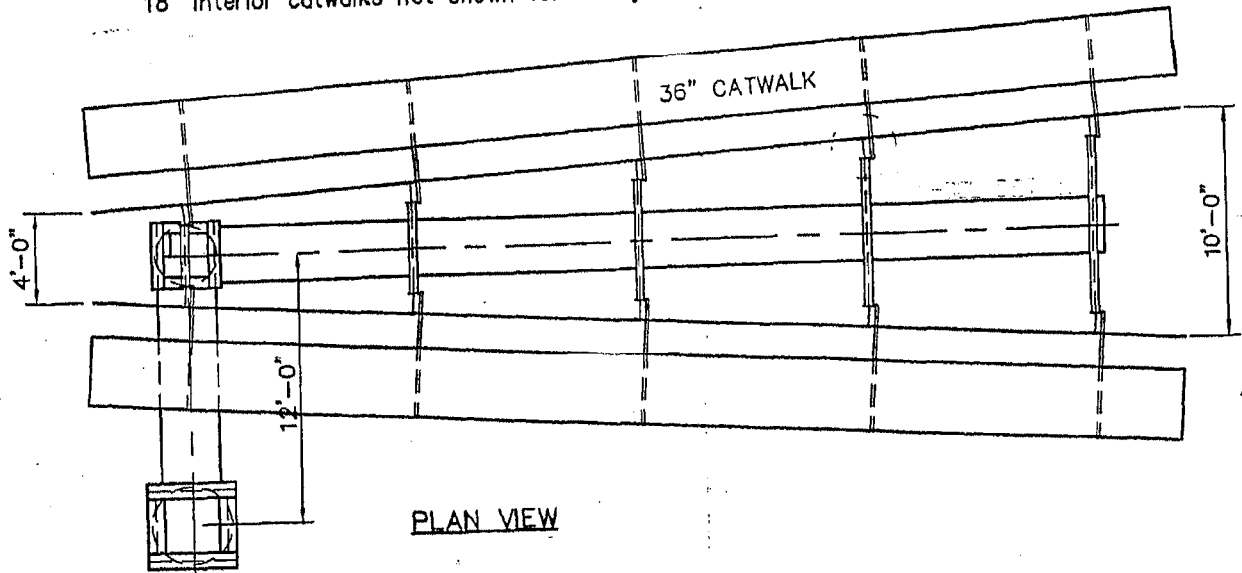
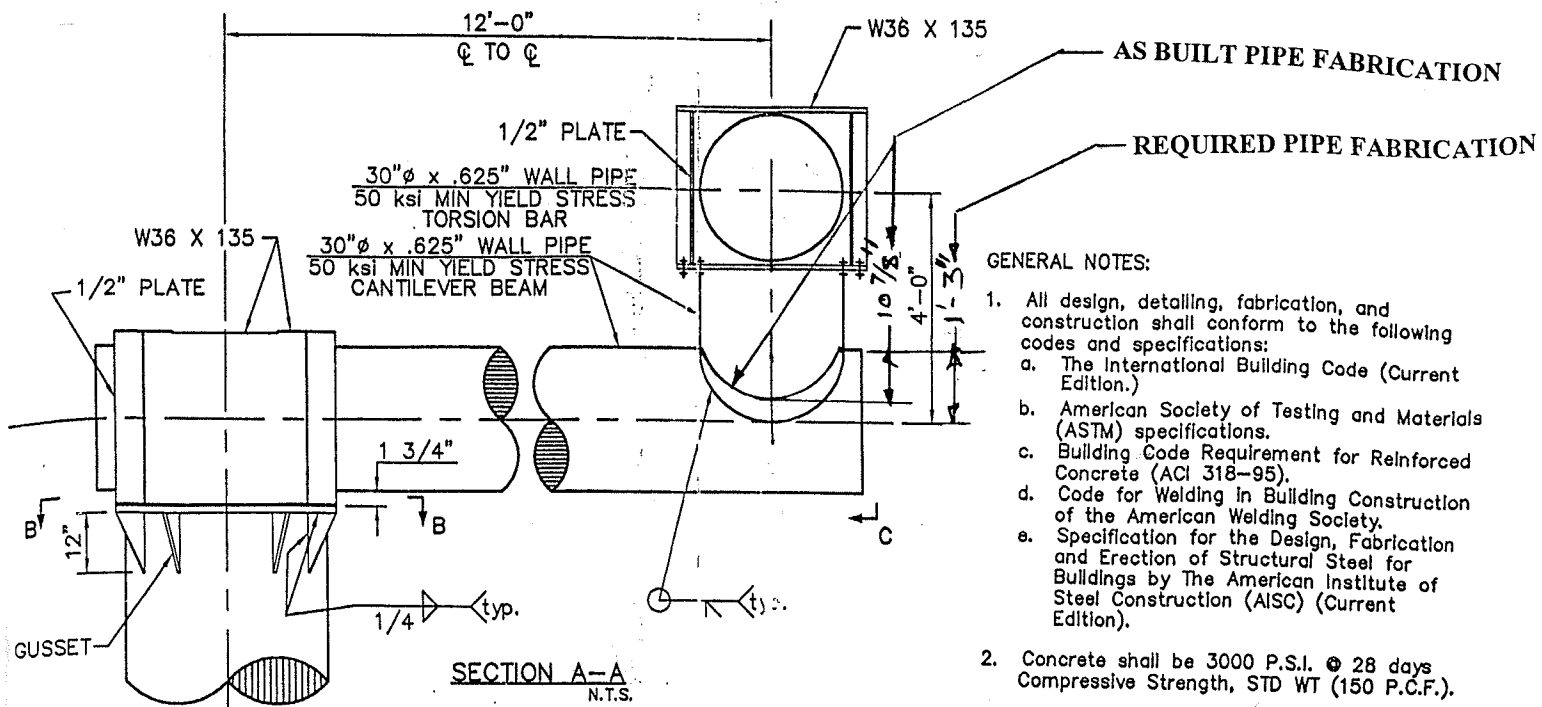

FIGURE 1 (REF. CONTRACT DRAWING)



GENERAL NOTES:

1. All design, detailing, fabrication, and construction shall conform to the following codes and specifications:
 - a. The International Building Code (Current Edition).
 - b. American Society of Testing and Materials (ASTM) specifications.
 - c. Building Code Requirement for Reinforced Concrete (ACI 318-95).
 - d. Code for Welding in Building Construction of the American Welding Society.
 - e. Specification for the Design, Fabrication and Erection of Structural Steel for Buildings by The American Institute of Steel Construction (AISC) (Current Edition).
2. Concrete shall be 3000 P.S.I. @ 28 days Compressive Strength, STD WT (150 P.C.F.).
3. Reinforcing Steel shall be ASTM A-615, Grade 60, (if required).
 - a. All reinforcing steel shall be free from mud, oil, rust or coatings that would reduce or destroy bond.
 - b. All reinforcing bars shall lap 30 diameters minimum, except as noted.
 - c. Minimum concrete cover on ties, stirrups and main bars shall be 3/4 inch for slab, wall and surfaces not exposed to weather or in contact with ground; 3 inches for unformed surfaces deposited against the ground except as noted.
4. Structural Steel and Plates shall be A-36. Structural tubing shall be ASTM A-500, Grade B, $F_y=46$ ksi. Structural piping shall be ASTM A-53, Grade B, Type E or S, $F_y=35$ ksi.
5. Anchor Bolts shall be ASTM A-307, unless otherwise noted.
6. High strength bolts for connections shall be ASTM A-325, unless otherwise noted.
7. Welding electrodes shall comply with AWS D1.1-97, E70xx.
8. Design Wind Speed = 90 MPH (I.B.C.). Equivalent Wind Load = 28.06 PSF @ 30 Feet above the ground.
9. Soil Bearing Capacity Requirements:
 - a. Spread Footings: Minimum Allowable Soil Bearing Capacity shall be P.S.F.
 - b. Cube or Auger Footings: Minimum Lateral Soil Bearing Capacity shall be 600 P.S.F. per foot of depth.
10. Contractor shall verify all dimensions and conditions in the field before erection and notify the Engineer of any discrepancies.
11. This structure is designed to accommodate Formetco trivision panels on each face. Panel weights are approximately 5400# each and are supported by the stringers.

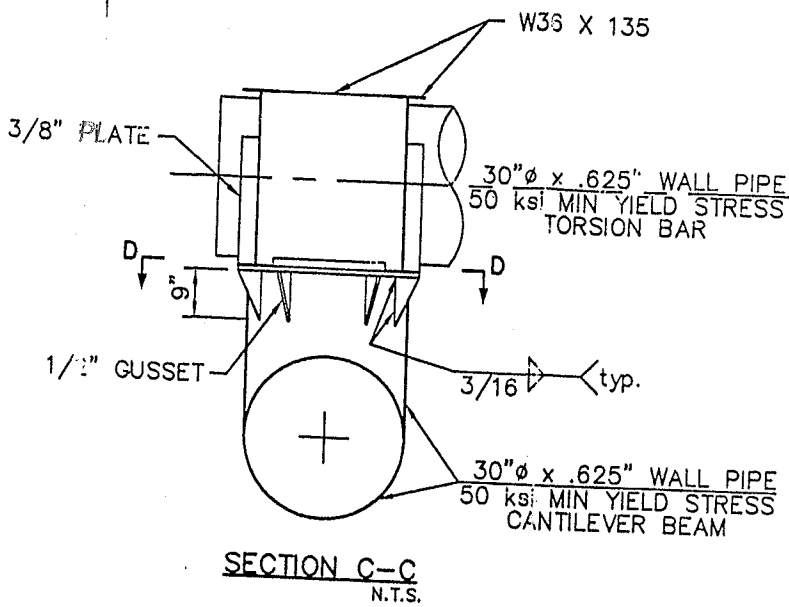

FIGURE 2 (REF. CONTRACT DRAWING)

**THE FIGURE ON THIS PAGE
INTENTIONALLY LEFT BLANK**

FIGURE 3



FIGURE 4



FIGURE 5



FIGURE 6



FIGURE 7