

**STRUCTURAL COLLAPSE AT THE
OLYMPIC SWIMMING VENUE
ATLANTA, GEORGIA
MARCH 18, 1996**



U.S. Department of Labor
Occupational Safety and Health Administration

June, 1996



**STRUCTURAL COLLAPSE AT THE
OLYMPIC SWIMMING VENUE
ATLANTA, GEORGIA
MARCH 18, 1996**



U.S. Department of Labor
Robert B. Reich, Secretary

Occupational Safety and Health Administration
Joseph A. Dear, Assistant Secretary

Directorate of Construction
Russell B. Swanson, Director

Office of Engineering Services
Mohammad Ayub

Michael L. Marshall
Fragrance Liu

June, 1996

TABLE OF CONTENTS

| | <u>Page Number</u> |
|---|--------------------|
| 1. INTRODUCTION | 1 |
| 2. DESCRIPTION OF THE PROJECT AND SITE CONDITIONS JUST PRIOR TO THE COLLAPSE | 5 |
| 2.1 Description of the Project | 5 |
| 2.2 Site Conditions Just Prior to Collapse | 7 |
| 3. WITNESS STATEMENTS | 14 |
| 4. SEQUENCE OF EVENTS RELATED TO FAILURE | 19 |
| 5. DESCRIPTION OF THE SITE AFTER THE COLLAPSE | 23 |
| 5.1 Overview of the Damage and Failed Structure | 23 |
| 5.2 Damaged Components of the Structure | 23 |
| 5.3 Physical Evidence Related to Witness Testimony | 24 |
| 6. STRUCTURAL ANALYSIS AND DISCUSSION | 36 |
| 7. OSHA STANDARDS and INDUSTRY PRACTICE | 49 |
| 8. CONCLUSIONS | 50 |
| APPENDIX A Computations | |
| APPENDIX B Industry Practice Related to Anchoring of Bridging | |
| APPENDIX C Laboratory Report and Addendum | |
| APPENDIX D SJI Letter dated June 7, 1996 | |

1. INTRODUCTION

On March 18, 1996, at approximately 6:15 to 6:30 p.m., a steel structure collapsed at the construction site for the Olympic Aquatic Center (pool), Atlanta, Georgia. The collapse occurred approximately 15 to 30 minutes after all personnel exited the area at the end of the workday. Therefore, no fatalities or injuries were sustained. The structure was near the beginning of the steel erection process when it failed. The site is located at the Georgia Institute of Technology Student Athletic Complex in Atlanta, GA.

Just prior to the failure, the steel erection crew had erected a steel frame and a pair of steel joists. The steel joists spanned approximately 176 ft. from an existing structure to the erected steel frame. At the time of failure, lateral support for the steel joists was being provided by the diagonal bridgings between the two joists placed at approximate 20 ft. intervals along the span. The bridgings were not anchored to any terminus point.

Figures 1.1 thru 1.4 show overall views of the site after the collapse of the structure.

The pool and its related structures have been commissioned by the Atlanta Committee for the Olympic Games, Inc. The Structural Engineer of Record is Stanley D. Lindsey, P.C.. Gaston-Thackett/Whiting Turner, a joint venture, is the construction management team at the site. Other contractors which played roles in this event include: 1) SMITH-OWEN STEEL COMPANY (SMITH-OWEN), structural steel supply contractor; 2) VULCRAFT, the steel joist designer and fabricator, subcontracted to SMITH-OWEN; and 3) HELMARK STEEL ERECTION (HELMARK), the steel erector, subcontracted to SMITH-OWEN.

On March 19, 1996, a compliance officer (CSHO) from the Atlanta-West, Area Office (AWAO), arrived at the site and began the incident investigation. Part of the CSHO's initial activities included observing and identifying physical evidences, identifying the companies and individuals involved in the event, and documenting the site through use of sketches, photographs and video tape.

On March 19, 1996, the OSHA Region IV, Deputy Regional Administrator contacted the Director of the OSHA Directorate of Construction, National Office, Washington, D.C. and requested on-site engineering assistance from the Office of Engineering Services (OES), to determine the cause(s) of the steel collapse. The scope of work included an evaluation of the design, fabrication, handling, and erection practices to determine if any deficiencies in those activities were contributory to the failure. Further, OES was tasked to determine if any identified contributory deficiencies were contrary to OSHA standards or industry practice.

Olympic Swimming Venue Structural Collapse

On March 20, 1996, a civil engineer from OES arrived on-site to assist in the incident investigation. Additionally, a safety engineer from the Region IV Technical Support Office joined the investigation team. Activities of the OSHA team included: 1) reviewing and requesting construction documents such as contract drawings, fabrication drawings, erection drawings, erection plan, etc.; 2) observations of the physical evidence; 3) documenting the site through photographs and sketches; 4) interviewing witnesses; 5) analyses of the failed structure; 6) creating and sustaining a dialogue between the Steel Joist Institute (SJI) - the industry consensus group for the design, fabrication, handling and erection of steel joists, the fabricator, the construction management team and the steel erector; 7) researching and compiling industry practice related to the steel joists' erection; and 8) obtaining several incident investigation reports from the contractors which had been impacted by the event, these reports were provided to OSHA as they became available throughout the course of the investigation.



Failed Steel Joists and Frame (Arrows)
(Looking east; Existing pool on right, Student Gymnasium in background)
Figure 1.1



Frame and Paired Joists on Ground
(Looking south-southwest; Existing pool in background)
Figure 1.2

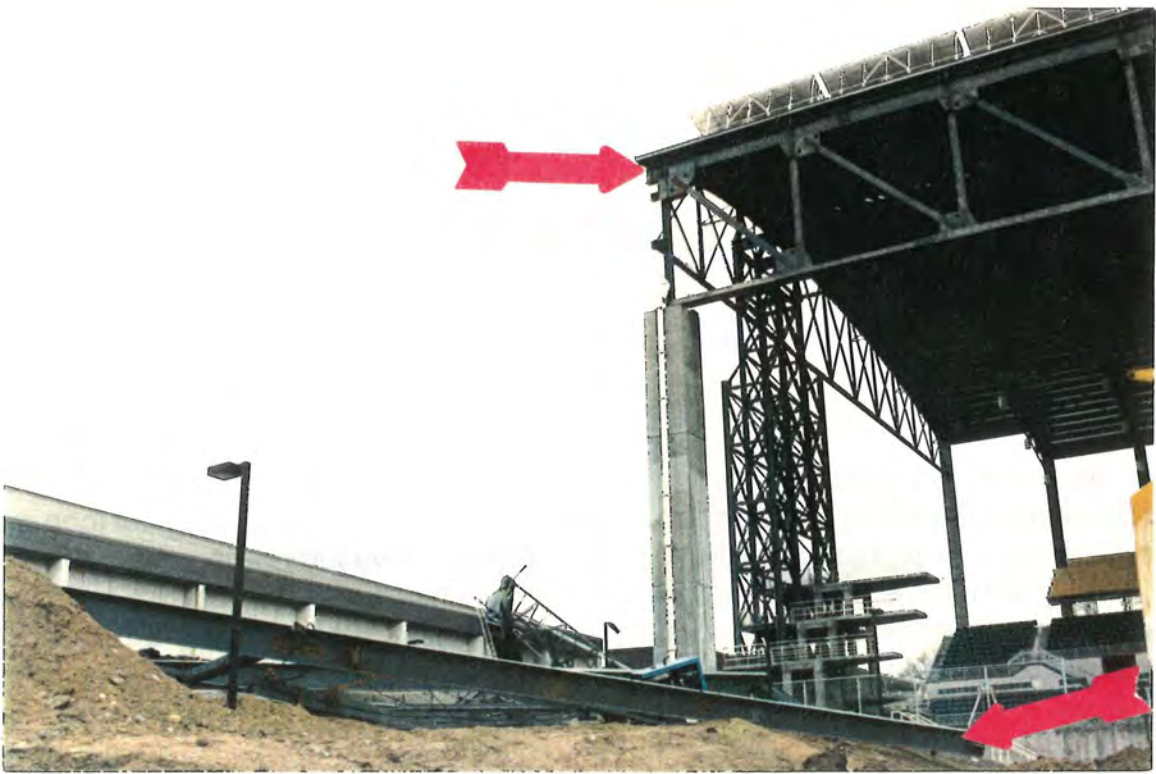

Failed Joists Supports - Frame on Ground & Existing Roof Beam (Arrow)
(Looking south-southeast)
Figure 1.3



South End of Collapsed Joists Resting On Roof of Student Gymnasium
(Looking southeast)
Figure 1.4

2. DESCRIPTION OF THE PROJECT AND SITE CONDITIONS JUST PRIOR TO THE COLLAPSE

2.1 Description of the Project

The structure which collapsed is designed as an addition to the existing pool structure. The existing pool includes a permanent roof structure. The purpose of the new construction is to provide a temporary roof over a grandstand area which is being built specifically for the Olympic Games. The new construction will be located along the entire length of the north side of the existing pool. After the Games, it is intended to remove the temporary north side construction, leaving the existing structure as part of the Georgia Tech Student Athletic Complex.

The size of the new structure is approximately 176'x 312'. Figure 2.1 is a framing plan¹ of the permanent roof and the new temporary roof which depicts details such as the location of the existing pool to the new construction, column lines, location and number of joists, etc.

Steel Frames

The design intent was to construct eleven bays of structural steel frames along column line 11, see Figure 2.1. These frames, along with the existing roof truss at column line 10, were to support the roof steel joists for the new addition. The steel joists, equally spaced over the roof structure, were used to support the roof decking. Figure 2.2 is the typical bracing detail² of a steel frame along column line 11.

The steel frames were supported by concrete footings. The height of the steel frames was approximately 130 ft. To provide additional temporary support during erection, temporary guy lines were installed on the steel frame at about $\frac{3}{4}$ of the height of the steel frame. The orientation of the guys was parallel to the longitudinal axis of the joist. Each frame column had two guys (one each on north and south side) anchored to deadman located about 100 ft. from the bases of the columns. To provide adequate tension, each temporary guy line was provided with a turnbuckle. The deadmen weighed about 10,000 lbs. each.

¹ *Framing Plan - Permanent Roof, Drawing Number - S3.3.2, 5/18/94, Stanley, Love-Stanley, P.C.*

² *Framing Sections and Details, Drawing Number S6.2, Section 3 - Elevation - Typical Bracing: 5/18/94, Stanley D. Lindsay, P.C.*

Steel Joists

The design of the structure consisted of roof framing by 49 steel joists supporting the roof deck. Figure 2.3 is an elevation³ which illustrates steel joists spanning from the steel frames at column line 11 to the existing roof truss on column line 10. The steel joists are designed and fabricated by VULCRAFT. The specified joists for the project are 88 SLH (88 inches deep, maximum allowable capacity of 210 lb/ft - Super Longspan designation). Figure 2.4 is a VULCRAFT fabrication drawing the typical 88 SLH, T-1 steel joist used for this structure. The overall span of these joists was greater than 176', which had exceeded the span specified by VULCRAFT in their SLH load tables⁴. Therefore, a special joist design was provided by VULCRAFT for the project.

Erection Sequence

The steel erector, HELMARK, opted to assemble two joists, as a pair, on the ground with all diagonal bridging lines installed. Eight sets of diagonal bridgings were installed along the span, and they were spaced at approximately 20 feet on centers. Figure 2.5 shows two photographs of paired joists which had been assembled on the ground. After the paired joists are assembled on the ground, they are rigged and lifted via a crane to be placed on their specified locations. After installing the first pair, HELMARK intended to continue erecting subsequent pairs of joists in the same fashion. Once the subsequent pairs were set, ironworkers were to connect the pairs together with the specified bolted diagonal bridgings.

HELMARK had two cranes at the site. One crane was utilized to lift the paired steel joists. The second crane was fitted with a personnel platform which was utilized by the ironworkers to gain access to the structure.

There was no written erection plan developed for this job. HELMARK developed a sketch after consulting with VULCRAFT for the rigging of the paired joists. Figure 2.6 is a copy of that sketch. This sketch was developed after an original attempt to lift a paired joists resulted in the failure of the welds in some of the joist members. The cause of the weld failures was alleged to be the stresses induced on the structure due to the inappropriate

³ *Roof Sections and Details; Drawing Number S6.1, 11/7/94 - revision #6, Stanley D. Lindsey, P.C.*

⁴ *Steel Joists and Joists Girders, #5: 1995, pg. 50, VULCRAFT*

rigging method employed. The contract documents⁵ state that the contractor must submit a written erection sequence prior to starting erection. Neither HELMARK nor SMITH-OWEN submitted an erection sequence plan.

According to HELMARK, temporary lateral bracing of the steel joists during erection was provided by the diagonal bridging lines installed between the pair of SLH joists which were set and bolted in-place. Other means of temporary bracing were deemed by HELMARK as infeasible such as the use of guy lines along the bridging lines. HELMARK said that the elevation and length of the joists versus available locations for guying anchors made this means of lateral bracing infeasible. They also asserted that the use of two cranes for lifting and holding two pairs of joists to provide lateral stability was not feasible because the restricted size and layout of the site made it unsafe for simultaneous lifting operations. In any event, anchoring of each of the bridging lines was not provided to the failed SLH paired joists.

2.2 Site Conditions Just Prior to Collapse

The following section discusses the conditions at the site just prior to the event. The weather at the site for the afternoon, up through the time of the event was reported by several witnesses to be calm.

The paired joists had been placed on the steel frame and existing structure. The crane's hoist line was released from the rigging and the crane was moved to a position to provide additional temporary support to the structure overnight as per the witness. The crane was rigged to the steel frame at column 11C.

After the crane was rigged to the steel frame, the workday ended. There were no people on the worksite when the incident occurred. Two ironworkers, who were exiting the job trailer, observed the structure fail. The failure occurred approximately 15 to 30 minutes after the crane was released from the paired joists.

In conclusion, there was no activity on-site or external forces, i.e., wind, operating material handling equipment, etc., which would have played a role in initiating the failure.

⁵ *Structural Notes; Drawing Number S0.1, Structural Steel Note #10: 9/30/94 latest revision, Stanley D. Lindsey, P.C.*

1. THE CONTRACTOR SHALL BE RESPONSIBLE FOR OBTAINING ALL NECESSARY PERMITS AND APPROVALS FROM THE APPLICABLE AGENCIES AND AUTHORITIES.
2. THE CONTRACTOR SHALL BE RESPONSIBLE FOR OBTAINING ALL NECESSARY PERMITS AND APPROVALS FROM THE APPLICABLE AGENCIES AND AUTHORITIES.
3. THE CONTRACTOR SHALL BE RESPONSIBLE FOR OBTAINING ALL NECESSARY PERMITS AND APPROVALS FROM THE APPLICABLE AGENCIES AND AUTHORITIES.



1. THE CONTRACTOR SHALL BE RESPONSIBLE FOR OBTAINING ALL NECESSARY PERMITS AND APPROVALS FROM THE APPLICABLE AGENCIES AND AUTHORITIES.
2. THE CONTRACTOR SHALL BE RESPONSIBLE FOR OBTAINING ALL NECESSARY PERMITS AND APPROVALS FROM THE APPLICABLE AGENCIES AND AUTHORITIES.
3. THE CONTRACTOR SHALL BE RESPONSIBLE FOR OBTAINING ALL NECESSARY PERMITS AND APPROVALS FROM THE APPLICABLE AGENCIES AND AUTHORITIES.

1. THE CONTRACTOR SHALL BE RESPONSIBLE FOR OBTAINING ALL NECESSARY PERMITS AND APPROVALS FROM THE APPLICABLE AGENCIES AND AUTHORITIES.
2. THE CONTRACTOR SHALL BE RESPONSIBLE FOR OBTAINING ALL NECESSARY PERMITS AND APPROVALS FROM THE APPLICABLE AGENCIES AND AUTHORITIES.
3. THE CONTRACTOR SHALL BE RESPONSIBLE FOR OBTAINING ALL NECESSARY PERMITS AND APPROVALS FROM THE APPLICABLE AGENCIES AND AUTHORITIES.

1. THE CONTRACTOR SHALL BE RESPONSIBLE FOR OBTAINING ALL NECESSARY PERMITS AND APPROVALS FROM THE APPLICABLE AGENCIES AND AUTHORITIES.
2. THE CONTRACTOR SHALL BE RESPONSIBLE FOR OBTAINING ALL NECESSARY PERMITS AND APPROVALS FROM THE APPLICABLE AGENCIES AND AUTHORITIES.
3. THE CONTRACTOR SHALL BE RESPONSIBLE FOR OBTAINING ALL NECESSARY PERMITS AND APPROVALS FROM THE APPLICABLE AGENCIES AND AUTHORITIES.

1. THE CONTRACTOR SHALL BE RESPONSIBLE FOR OBTAINING ALL NECESSARY PERMITS AND APPROVALS FROM THE APPLICABLE AGENCIES AND AUTHORITIES.
2. THE CONTRACTOR SHALL BE RESPONSIBLE FOR OBTAINING ALL NECESSARY PERMITS AND APPROVALS FROM THE APPLICABLE AGENCIES AND AUTHORITIES.
3. THE CONTRACTOR SHALL BE RESPONSIBLE FOR OBTAINING ALL NECESSARY PERMITS AND APPROVALS FROM THE APPLICABLE AGENCIES AND AUTHORITIES.

1. THE CONTRACTOR SHALL BE RESPONSIBLE FOR OBTAINING ALL NECESSARY PERMITS AND APPROVALS FROM THE APPLICABLE AGENCIES AND AUTHORITIES.
2. THE CONTRACTOR SHALL BE RESPONSIBLE FOR OBTAINING ALL NECESSARY PERMITS AND APPROVALS FROM THE APPLICABLE AGENCIES AND AUTHORITIES.
3. THE CONTRACTOR SHALL BE RESPONSIBLE FOR OBTAINING ALL NECESSARY PERMITS AND APPROVALS FROM THE APPLICABLE AGENCIES AND AUTHORITIES.

1. THE CONTRACTOR SHALL BE RESPONSIBLE FOR OBTAINING ALL NECESSARY PERMITS AND APPROVALS FROM THE APPLICABLE AGENCIES AND AUTHORITIES.
2. THE CONTRACTOR SHALL BE RESPONSIBLE FOR OBTAINING ALL NECESSARY PERMITS AND APPROVALS FROM THE APPLICABLE AGENCIES AND AUTHORITIES.
3. THE CONTRACTOR SHALL BE RESPONSIBLE FOR OBTAINING ALL NECESSARY PERMITS AND APPROVALS FROM THE APPLICABLE AGENCIES AND AUTHORITIES.

1. THE CONTRACTOR SHALL BE RESPONSIBLE FOR OBTAINING ALL NECESSARY PERMITS AND APPROVALS FROM THE APPLICABLE AGENCIES AND AUTHORITIES.
2. THE CONTRACTOR SHALL BE RESPONSIBLE FOR OBTAINING ALL NECESSARY PERMITS AND APPROVALS FROM THE APPLICABLE AGENCIES AND AUTHORITIES.
3. THE CONTRACTOR SHALL BE RESPONSIBLE FOR OBTAINING ALL NECESSARY PERMITS AND APPROVALS FROM THE APPLICABLE AGENCIES AND AUTHORITIES.

1. THE CONTRACTOR SHALL BE RESPONSIBLE FOR OBTAINING ALL NECESSARY PERMITS AND APPROVALS FROM THE APPLICABLE AGENCIES AND AUTHORITIES.
2. THE CONTRACTOR SHALL BE RESPONSIBLE FOR OBTAINING ALL NECESSARY PERMITS AND APPROVALS FROM THE APPLICABLE AGENCIES AND AUTHORITIES.
3. THE CONTRACTOR SHALL BE RESPONSIBLE FOR OBTAINING ALL NECESSARY PERMITS AND APPROVALS FROM THE APPLICABLE AGENCIES AND AUTHORITIES.

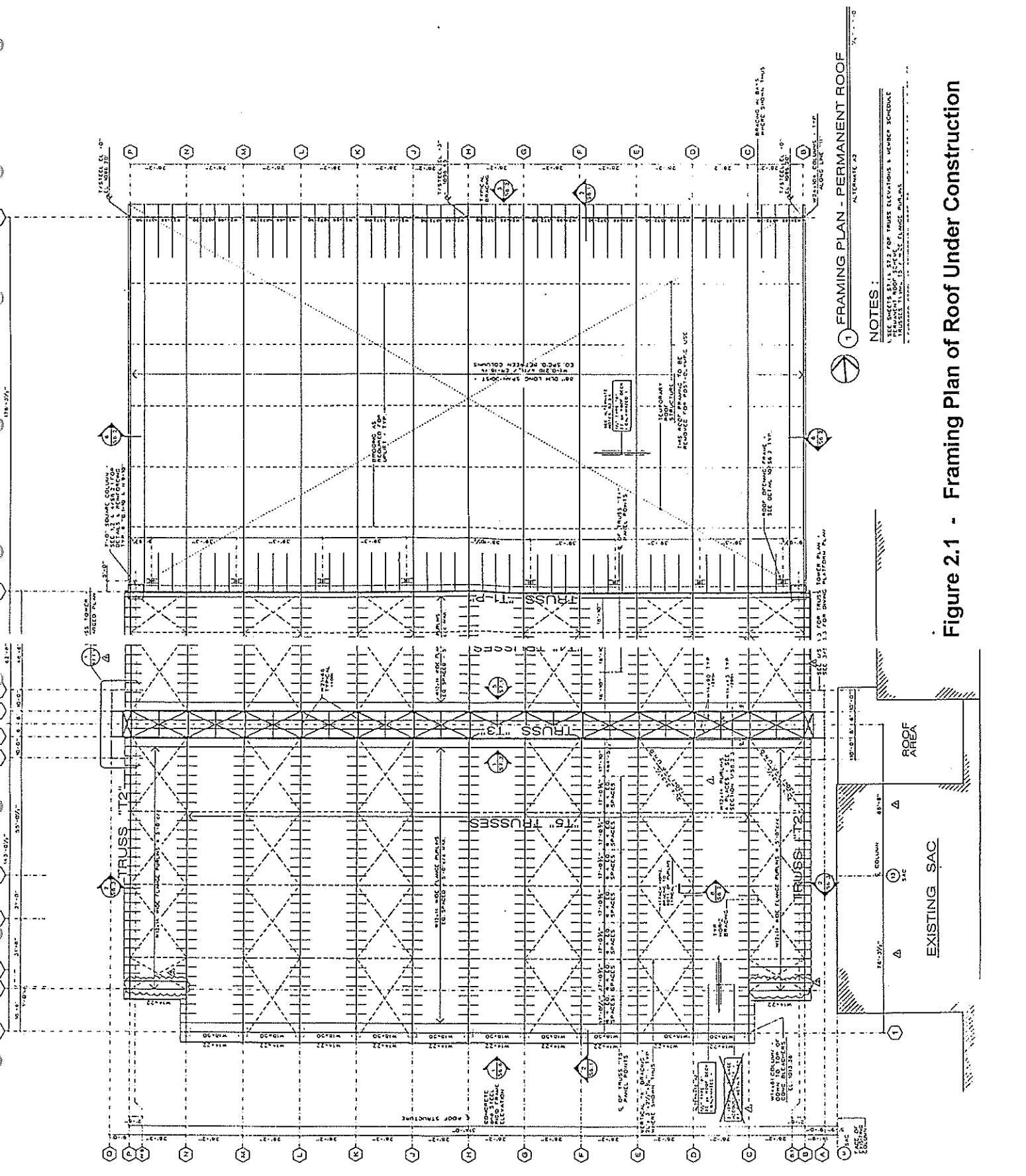

1 FRAMING PLAN - PERMANENT ROOF
ALTERNATE A2

NOTES:
1. SEE SHEETS 0311, 0312 FOR BRACE ELEVATIONS & MEMBER SCHEDULE.
2. TEMPORARY STRUCTURE FOR POST-CONSTRUCTION USE.
3. SEE SHEETS 0311, 0312 FOR BRACE ELEVATIONS & MEMBER SCHEDULE.

Figure 2.1 - Framing Plan of Roof Under Construction

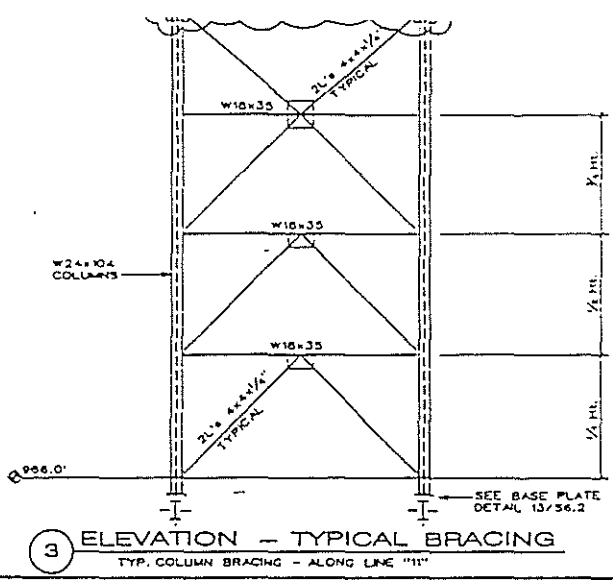
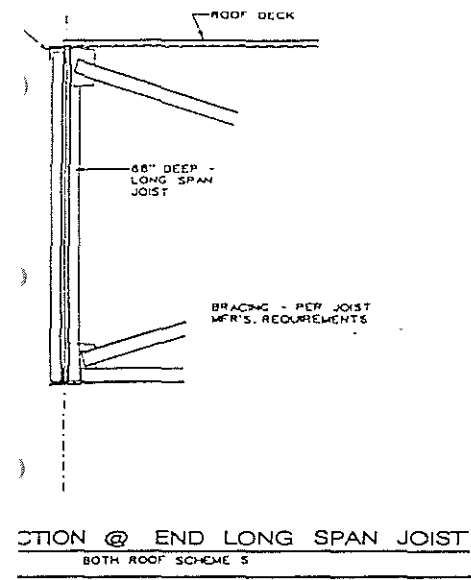

OLYMPIC AQUATIC CEI
 GEORGIA INSTITUTE OF TECHNOLOGY
 STUDENT ATHLETIC COMPLEX
 ATLANTA, GEORGIA

Atlanta Committee for Olympic Games, Inc.



Stanley, Lova-Stanley, P.C./
 Kramwood, Reynolds,
 Stewart, Stewart &
 Associates, Inc. A Joint Venture

Stanwood, Reynolds,
 Stewart, Stewart &
 Associates, Inc.

One Piedmont Center, Suite 303
 3565 Piedmont Road
 Atlanta, Georgia 30305-1521
 (404) 253-5453

Stanley, Lova-Stanley, P.C.
 600 W. Peachtree Street NW, Suite 1420
 Atlanta, Georgia 30308
 (404) 876-3053

Structural Engineer
 Lindsey/Harrington

Stanley D. Lindsey & Associates, Ltd.
 2300 Winny Ridge Parkway SE
 Suite 100 South
 Marietta, Georgia 30308
 (404) 850-1347

Harrington Engineers, Inc.
 2981 Church Street, Suite 212
 East Point, Georgia 30344
 (404) 761-0767

Mechanical, Electrical, Plumbing &
 Fire Protection Consultants

Kevecomb & Boyd/Deamers Systems
 Kevecomb & Boyd Consulting Engineers
 One Northside 75
 Atlanta, Georgia 30318-7761
 (404) 352-3550

Deamers Systems
 451 Memorial Drive, Suite 204F
 Decatur, Georgia 30032
 (404) 292-6206

Civil Engineering

B.K. Jackson & Associates
 34 Peachtree Street, Suite 2100
 Atlanta, Georgia 30303
 (404) 577-4914

Pool Consultants

Cousins/Hessmer & Associates
 4365 Anders Road
 St. Louis, Missouri 63128
 (314) 894-1245

| PRINTED | | REVISIONS | |
|----------|-------------------------|-----------|-------------------------|
| DATE | REMARKS | DATE | REMARKS |
| 12/11/94 | ISSUED FOR CONSTRUCTION | 4/10/94 | ISSUED FOR CONSTRUCTION |
| 2/28/94 | ISSUED FOR CONSTRUCTION | 3/22/94 | REVISION #1 |
| 3/28/94 | ISSUED FOR CONSTRUCTION | 4/10/94 | REVISION #2 |
| 4/10/94 | ISSUED FOR CONSTRUCTION | 4/10/94 | REVISION #3 |
| 4/10/94 | ISSUED FOR CONSTRUCTION | 4/10/94 | REVISION #4 |
| 4/10/94 | ISSUED FOR CONSTRUCTION | 4/10/94 | REVISION #5 |

Drawn by: JRM Reviewed by: JEF/AM

Drawing Title: FRAMING SECTIONS & DETAILS

Key Plan:

| | |
|--------------|---------|
| Proj. No.: | SN0602 |
| AS NOTED | |
| Fig. Number: | S6.2 |
| Date: | 5/18/94 |

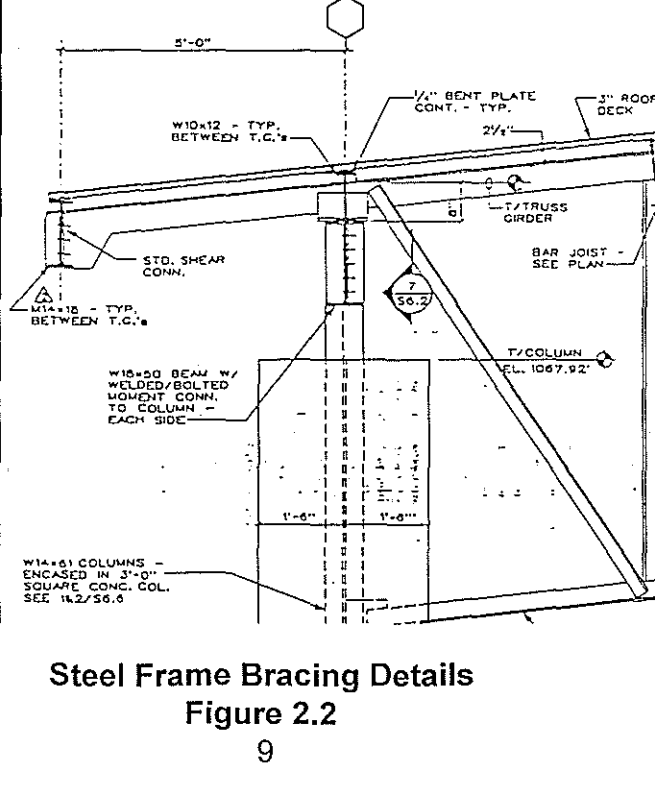
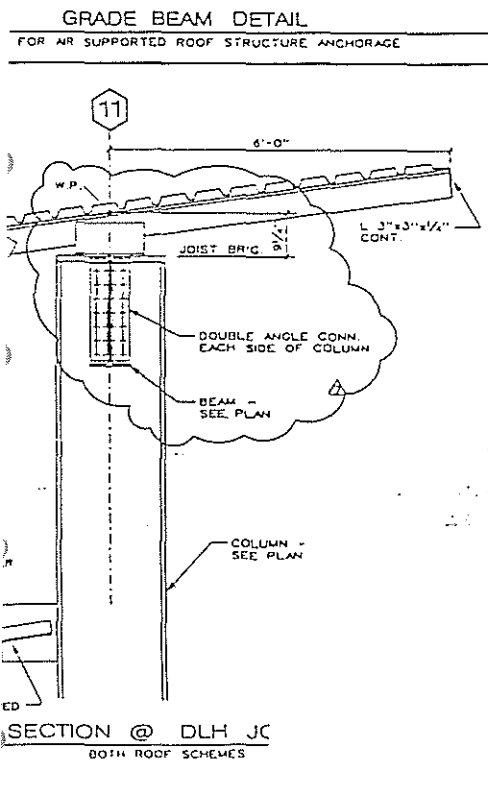
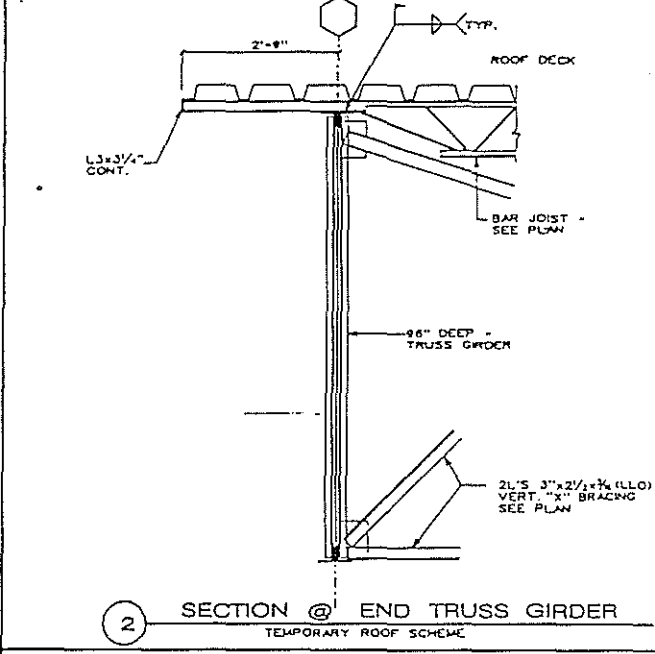
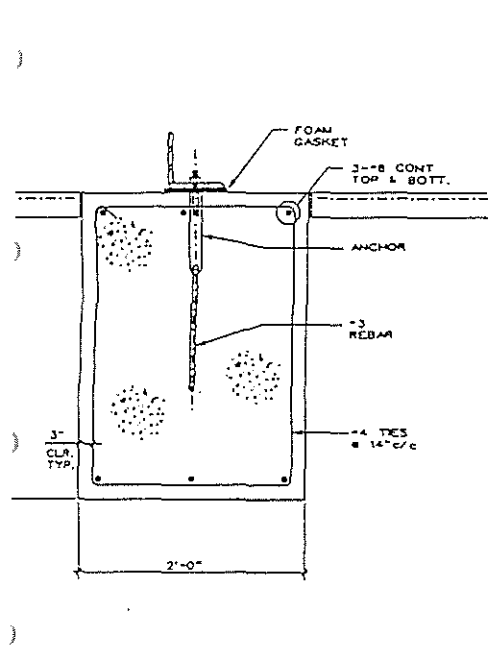

Steel Frame Bracing Details
Figure 2.2

OLYMPIC AQUATIC CENTER

GEORGIA INSTITUTE OF TECHNOLOGY
ATLANTA, GEORGIA

Atlanta Olympic Committee for the



ARCHITECT
 HOK, Inc.
 100 Peachtree Street, N.W.
 Atlanta, Georgia 30309
 Telephone: (404) 521-8000
 Telex: 53000 HOK
 Fax: (404) 521-8000

STRUCTURAL ENGINEER
 HOK, Inc.
 100 Peachtree Street, N.W.
 Atlanta, Georgia 30309
 Telephone: (404) 521-8000
 Telex: 53000 HOK
 Fax: (404) 521-8000

DATE REVISIONS

| DATE | REVISIONS | BY | REVISIONS |
|----------|-----------------------|-----|-----------|
| 12/15/88 | ISSUED FOR PERMITTING | ... | ... |
| ... | ... | ... | ... |

ROOF SECTIONS & DETAILS

1/1 Part 1

DATE: 12/15/88
 DRAWN BY: ...
 CHECKED BY: ...
 PROJECT: OLYMPIC AQUATIC CENTER
 SHEET: S6.1
 OF: 1

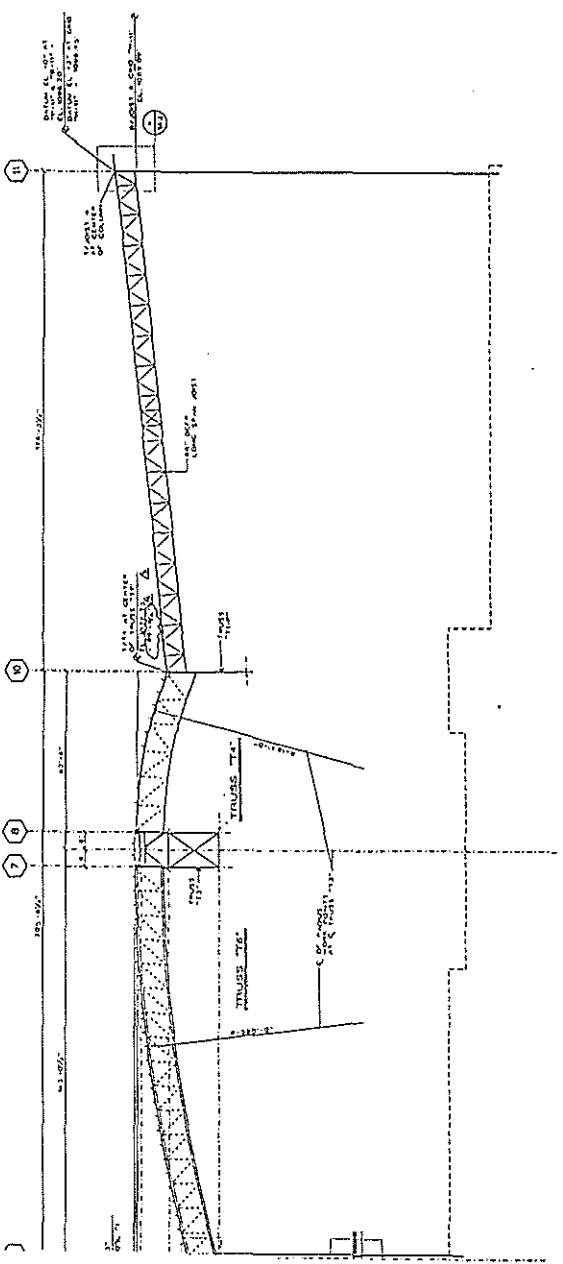

2 SECTION IN-VU TRUSS FRAMING
 FOR PERMITTING AND RECORD

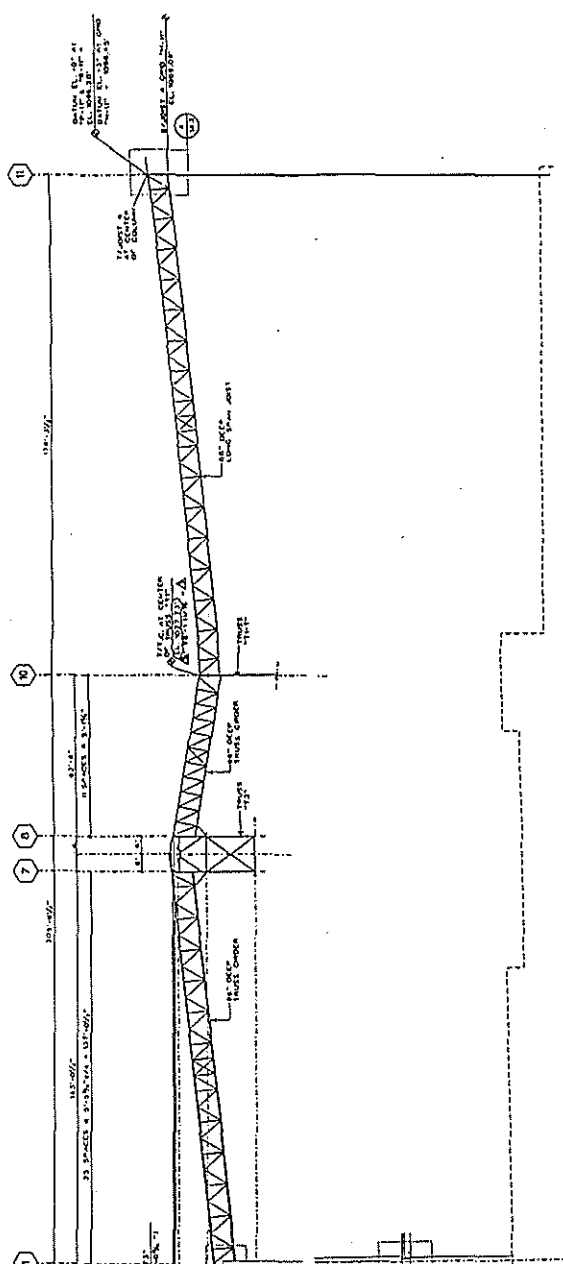

1 SECTION IN-VU TRUSS FRAMING
 FOR PERMITTING AND RECORD

Elevation Showing Joists Spanning Between Supports
Figure 2.3

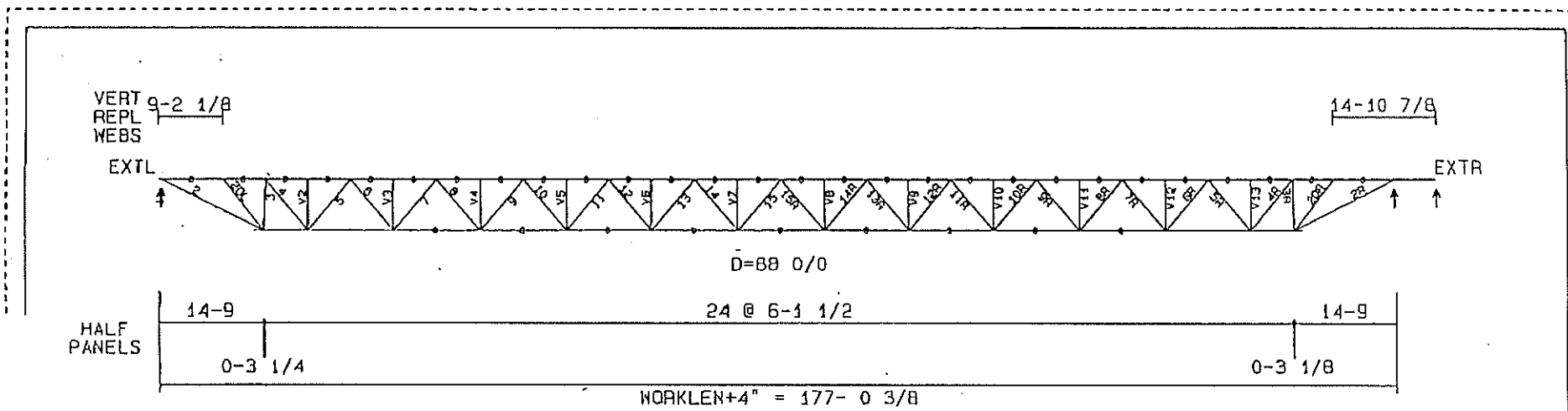

EXTL = 0- 2 1/8 TOP CHORD 2 L 4 X 4 X .375 EXTR = 5-10 7/8
 BCXL = 1- 3 3/4 BOTTOM CHORD 2 L 4 X 4 X .375 BCXR = 1- 3 3/4

| WEB | QTY | SIZE | WELD SIZE | WEB | QTY | SIZE | WELD SIZE |
|-----|-----|----------------------|-------------|-----|-----|----------------------|-------------|
| 2 | 2* | L 3-1/2X 3-1/2X .287 | 12.1X0.224 | 15R | 2* | L 2 X 2 X .205 | 2.3X0.187 |
| 2DL | 2* | L 2 X 2 X .205 | 2.1X0.187 G | V8 | 2* | L 1-1/2X 1-1/2X .113 | 2.0X0.113 |
| 3 | 2* | L 2-1/2X 2-1/2X .188 | 5.7X0.187 | 14R | 2* | L 1-3/4X 1-3/4X .144 | 6.8X0.144 |
| 4 | 2* | L 1-3/4X 1-3/4X .188 | 7.0X0.187 | 13R | 2* | L 2 X 2 X .205 | 2.3X0.187 |
| V2 | 2* | L 1-1/2X 1-1/2X .113 | 2.0X0.113 G | V9 | 2* | L 1-1/2X 1-1/2X .113 | 2.0X0.113 |
| 5 | 2* | L 2-1/2X 2-1/2X .188 | 6.4X0.187 | 12R | 2* | L 1-3/4X 1-3/4X .144 | 6.8X0.144 |
| 6 | 2* | L 1-3/4X 1-3/4X .155 | 7.0X0.155 | 11R | 2* | L 2 X 2 X .205 | 2.7X0.187 |
| V3 | 2* | L 1-1/2X 1-1/2X .113 | 2.0X0.113 G | V10 | 2* | L 1-1/2X 1-1/2X .113 | 2.0X0.113 |
| 7 | 2* | L 2-1/2X 2-1/2X .188 | 5.2X0.187 | 10R | 2* | L 1-3/4X 1-3/4X .144 | 6.8X0.144 |
| 8 | 2* | L 1-3/4X 1-3/4X .144 | 6.8X0.144 | 9R | 2* | L 2 X 2 X .205 | 4.0X0.187 |
| V4 | 2* | L 1-1/2X 1-1/2X .113 | 2.0X0.113 | V11 | 2* | L 1-1/2X 1-1/2X .113 | 2.0X0.113 |
| 9 | 2* | L 2 X 2 X .205 | 4.0X0.187 | 8R | 2* | L 1-3/4X 1-3/4X .144 | 6.8X0.144 |
| 10 | 2* | L 1-3/4X 1-3/4X .144 | 6.8X0.144 | 7R | 2* | L 2-1/2X 2-1/2X .188 | 5.2X0.187 |
| V5 | 2* | L 1-1/2X 1-1/2X .113 | 2.0X0.113 | V12 | 2* | L 1-1/2X 1-1/2X .113 | 2.0X0.113 G |
| 11 | 2* | L 2 X 2 X .205 | 2.7X0.187 | 6R | 2* | L 1-3/4X 1-3/4X .155 | 7.0X0.155 |
| 12 | 2* | L 1-3/4X 1-3/4X .144 | 6.8X0.144 | 5R | 2* | L 2-1/2X 2-1/2X .188 | 6.4X0.187 |
| V6 | 2* | L 1-1/2X 1-1/2X .113 | 2.0X0.113 | V13 | 2* | L 1-1/2X 1-1/2X .113 | 2.0X0.113 G |
| 13 | 2* | L 2 X 2 X .205 | 2.3X0.187 | 4R | 2* | L 1-3/4X 1-3/4X .188 | 7.0X0.187 |
| 14 | 2* | L 1-3/4X 1-3/4X .144 | 6.8X0.144 | 3R | 2* | L 2-1/2X 2-1/2X .188 | 5.7X0.187 |
| V7 | 2* | L 1-1/2X 1-1/2X .113 | 2.0X0.113 | 2DR | 2* | L 2 X 2 X .205 | 2.1X0.187 G |
| 15 | 2* | L 2 X 2 X .205 | 2.3X0.187 | 2R | 2* | L 3-1/2X 3-1/2X .287 | 12.0X0.224 |

T1 88SLH Joist Fabrication Drawing by VULCRAFT

Figure 2.4

11



PAIRED JOISTS ASSEMBLED ON GROUND

Top Photo shows two pairs (4 - 88 SLH joists) assembled on ground, ready to be hoisted

Right photo shows diagonal bridging between two joists

Figure 2.5



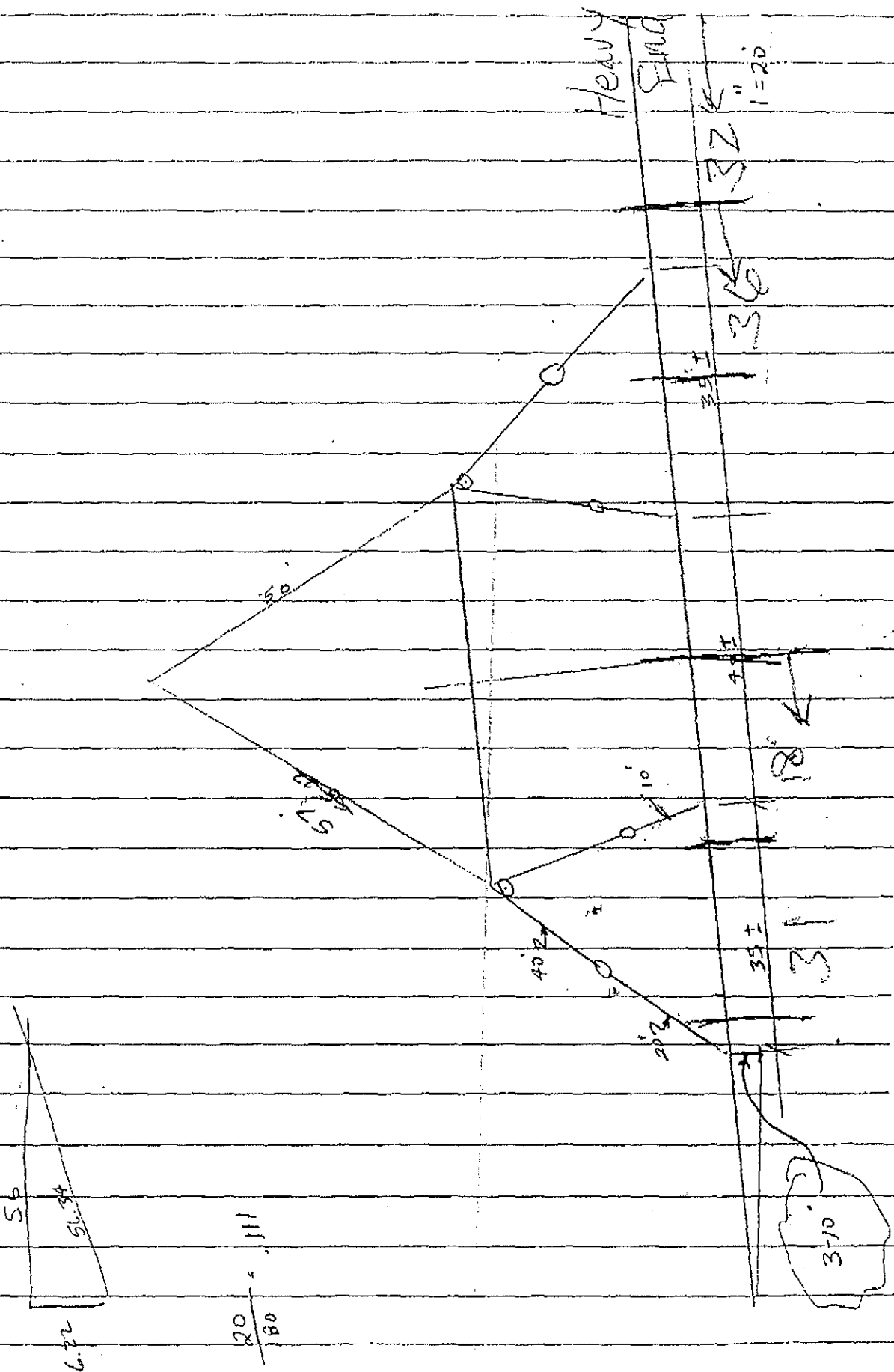

Figure 2.6 - Helmark's Rigging Sketch For Hoisting the Paired Joists

3. WITNESS STATEMENTS

The following section gives an overview of witness statements which were obtained by OSHA. The overview includes only those witnesses, either direct eyewitnesses or other witnesses with pertinent information. The table below includes a witness identifier, company, location at time of event, and a description of their pertinent information.

| Company Job Title | Location @ Time of Event | Information |
|--------------------------|--|--|
| 1. HELMARK Ironworker | Door of job-site trailer looking east toward structure | <ul style="list-style-type: none"> o Observed paired joists deflect near midspan in downward direction. o After the midspan deflected the paired joists began to roll and simultaneously bow laterally toward him (west). o The failure of the structure occurred within 30 minutes of releasing the crane from the paired joists. o According to his watch, the collapse occurred @ 6:29 p.m. o Erection crew had erected the steel frame bent at ≈ 9:00 am at the day of event. They had installed temporary support guys on the bent a day earlier. o Installation of the steel frame bent @ Column Line 11B&C included 4 anchor bolts/column, impact wrenched tight; two guys/column installed ≈ ¾ up the elevation; guys were installed perpendicular to the plane of the frame; plumbed bent w/transit; connected guys to 10,000 lb. deadmen; and tensioned all 4 guys with turnbuckles. The center splices on the paired joists were bolted wrench tight and latter torqued by bolt crew. o All bolts were impacted before paired joists left ground. o Identified sketch used by ironworkers to rig paired joists to be hoisted. |

Olympic Swimming Venue Structural Collapse

| Company Job Title | Location @ Time of Event | Information |
|--|--|---|
| <p>2. HELMARK Raising Gang Foreman</p> | <p>Door of job-site trailer looking east toward structure.</p> | <ul style="list-style-type: none"> o Was in job-site trailer with 4 other people discussing next days plans. o Opened trailer door @ ≈ 6:26 p.m. to leave for the day and observed the structure collapse. o Observed the center span “surge” down and roll toward the trailer (west). Next, he observed the steel frame (north end) bend over to the southeast, followed by the pool end (south) of the paired joists coming off the existing structure. o Ironworkers used sketches to rig the steel frame bent and paired joists (which ultimately failed). o Used crane to hoist paired joists into place. The connectors first tied the south end into the existing structure. Next they connected the north end to the steel frame. They were required to loosen the turnbuckles for the temporary guys to align the bolt holes. After the bolts were inserted, the steel frame was replumbed and the guys were retensioned. Made all bolts “snug”. o Instructed connectors to bring piece (paired joists) down (slack the hoist line so load is taken by structure) to see how it feels (determine if structure is capable of supporting itself). o Connectors had crane operator come down (slack line) and released the 1st rigging sling (closest to north side). o Connectors told him via radio, they were concerned about excessive movement of the paired joists as weight was being transferred from crane to the structure. |

Olympic Swimming Venue Structural Collapse

| Company Job Title | Location @ Time of Event | Information |
|---|-----------------------------|---|
| <p>2. HELMARK Raising Gang Foreman</p> <p>(Continued)</p> | | <ul style="list-style-type: none"> o Got in manbasket and was hoisted up to the paired joists where he got onto the joists to observe the conditions. o While on paired joists, felt it wasn't secure. Described excessive flexing and torsion in the joists as he moved on the structure. o Made decision that connectors would not continue cutting the individual slings loose by walking along the joists, instead told connectors to work from a man basket and to cut the rigging loose at the hoist line hook. This action was done by connectors. o Instructed crane operator to move crane around and to hook up to rigging which was installed on Column 11C. This was done to secure the crane versus providing additional temporary structural support. They secured crane because it was getting dark and near the end of the work shift. o They utilized VULCRAFT erection drawing to assist them in the erection. o No discussion was held w/other HELMARK site management about providing temporary lateral bracing during erection such as additional guys, another erection crane. etc. |

Olympic Swimming Venue Structural Collapse

| Company Job Title | Location @ Time of Event | Information |
|--|-----------------------------|--|
| <p>3. HELMARK Ironworker (Connector)</p> | <p>Not on-site</p> | <ul style="list-style-type: none"> o Was one of two connectors which set paired joists in-place. o After landing paired joists on existing structure support, used 4 A325 bolts, wrench tight, to secure side to support. Then moved to steel frame bent side and connected paired joists with 4 bolts wrench tight. o The connectors then started cutting chokers, e.g. releasing sling rigging, from the bent side of the structure. The bent end of the paired joists "felt good", i.e. stable. o As connectors walked on the paired joists "the camber felt like it was coming down a little bit". o They didn't want to cut the 2nd choker because of the deflection in the structure. They waited about 10 minutes, to observe if the structure would stabilize. o To be safe, they got in a manbasket and cut the 2nd choker loose from the paired joists. From that point, the rigging was cut free from the hoist line of the crane. o The crane was moved to the northwest side of Column 11C and hooked to rigging which was installed on the column. The purpose of this rigging was to insure, "the bent wouldn't fall on the building (gymnasium) with people in it." o From his experience, there was excess deflection in the camber of the paired joists. |

Olympic Swimming Venue Structural Collapse

| Company Job Title | Location @ Time of Event | Information |
|--|-----------------------------|--|
| <p>4. HELMARK Ironworker (Connector)</p> | <p>Not on-site</p> | <ul style="list-style-type: none"> o Set the end of the paired joists on the existing structure side. o Next, made the connection to the steel bent, which required slacking of temporary guy cables, replumbing bent, tightening bolts and tensioning turnbuckles. o Let piece (paired joists) down by slacking hoist line. The piece settled. o Cut the first rigging sling nearest the steel frame, as the piece settled, the piece suddenly "surged down". o Cut the 2nd choker, then the piece "surged down" a second time. o At this point he saw paint peel right adjacent to a splice in the joists. He felt this was caused by stress in the piece. o The connectors on the structure called down to raising gang foreman for advice and direction. o The foreman came up to the structure to observe the situation and advised that the instability of the structure was a concern and directed the connectors to work from a man basket to cut the rigging loose from the crane hook. o This is the first structural steel this connector has ever come off because of safety, i.e. stability, concerns . Because of the structure's stability he felt it was the proper course of action to complete the rigging down activity from the man basket. o There was a storm coming in so they moved the crane to Column 11C and connected the crane to a choker they had rigged to the column leg. The purpose of this operation was to provide additional stability to the structure in the event the storm induced forces on the structure which would cause it to possibly fail onto the gymnasium. |
| <p>5. HELMARK Crane Operator</p> | <p>Not on-site</p> | <ul style="list-style-type: none"> o Told the weight of the load was 20,000 lbs. and 18,000 lbs. by two respective HELMARK managers. Used 20,000 lbs. as load weight. o In 20 years of crane operation he had never observed a piece wiggle or move as much as the paired joists did when it was hoisted. |

4. SEQUENCE OF EVENTS RELATED TO FAILURE

The following section details a sequence of events preceding and through the time of the collapse. The time line lists activities which were related to the event. Where important, specific dates and times are listed. Some items include discussion which states the relevance of the item.

Time line Related to the Collapse

| Date/Time | Activity |
|-------------------------------------|---|
| 1. 1995 | Atlanta Olympic Aquatic Center (existing structure) is constructed and opened. |
| 2. Prior to March 1996 | <ul style="list-style-type: none"> o VULCRAFT designs and fabricates the 88 SLH joists to be used for temporary roof during Olympic games. o VULCRAFT ships joists to site. |
| 3. March 1996 | <ul style="list-style-type: none"> o HELMARK erects joists as pairs on the ground at site. o HELMARK attempts to move a paired joist via crane on-site. As a result "several" welds fail when the paired joists are lifted. o VULCRAFT representatives arrive at site to examine joists. o VULCRAFT gives instruction on how to reweld the failed connections. o Additionally, VULCRAFT gave HELMARK advice on how to rig the paired joists for the next lift. o The repaired joists was set aside and <u>was not</u> the paired joist that failed during the event. |
| 4. March 11, 1996 | Concrete footings poured for steel frame at column 11B & 11C. |
| 5. March 17, 1996 | o Steel frame between column line 11B & 11C is assembled on the ground. |
| 6. March 18, 1996 (Day of event) | o The steel frame was erected by the HELMARK ironworkers at columns 11B & 11C. This included: a) raising the frame with the crane; b) bolting the frames legs (columns) to the concrete footings; c) connecting the temporary guy supports to deadmen; d) plumbing the frame; and e) tensioning the guys. See Figure 4.1. |
| 7. March 18, 1996 | o A paired joist was rigged and hoisted into place. |
| 8. March 18, 1996 | o The south end (existing structure side) of the paired joists were bolted in-place. See Figure 4.2. |
| 9. March 18, 1996 | o An attempt was made by the ironworkers to bolt the north end (steel frame end) of the joists, however, "minor" (as per ironworkers) alignment problems resulted in the joists and frames not being able to be bolted. |

Olympic Swimming Venue Structural Collapse

| Date/Time | Activity |
|--|---|
| | <ul style="list-style-type: none"> o The tension on the temporary guy cables on the steel frame were readjusted to allow for the alignment of the bolt holes on the frame and joists. The north side of the joists were then bolted. |
| <p>10. March 18, 1996 (Day of Event)</p> | <ul style="list-style-type: none"> o The steel frame was then replumbed by the ironworkers. |
| <p>11. March 18, 1996</p> | <ul style="list-style-type: none"> o Two ironworkers (connectors) began the process of disconnecting the four slings used to hold the paired joists. This process began on the north side of the joists. The disconnecting process was being done with the connectors on the structure. |
| <p>12. March 18, 1996</p> | <ul style="list-style-type: none"> o After disconnecting the first sling, one of the connectors on the structure became concerned with the stability of the paired joists. The connectors concerns included a precieved excess deflection, which was characterized by a "surging" of the paired joists in a downward direction. |
| <p>13. March 18, 1996</p> | <ul style="list-style-type: none"> o After the second sling was released, a connector experienced a second "surge" in the paired joists. As a result of the connectors concerns, the foreman (originally located on the ground during the lifting and connecting process) was lifted to the structure via a personnel platform to observe the conditions. The foreman concurred with the connectors concerns. Subsequent works were conducted from the personnel platform because of the concerns related to the stability of the paired joists. |
| <p>14. March 18, 1996 ≈ 6:00 pm</p> | <ul style="list-style-type: none"> o The connectors decided to leave the other two slings connected to the structure and to disconnect the crane from the paired joist at the hook-rigging shackles connection. |
| <p>15. March 18, 1996</p> | <ul style="list-style-type: none"> o As the work day was nearing completion the crane was moved to the steel frame and connected to the frame at column 11C. Although there is some conjecture to this point, the ironworker supervisor stated the reason the crane was moved to this point and rigged to the column was to secure the crane for the night. |
| <p>16. March 18, 1996 ≈ 6:15 - 6:30 pm</p> | <ul style="list-style-type: none"> o Most workers had exited the job site, except four remained in the job trailer at the time of collapse. Two of the four employees were in the process of exiting the trailer when they observed the joist pair deflect downward near mid span and rotate toward the west. As the joists rotated, the connected ends came off their supports, with the north end pulling the steel frame to the southeast and the south end deflecting to the east and falling on the roof of the Student Athletic Gymnasium. |

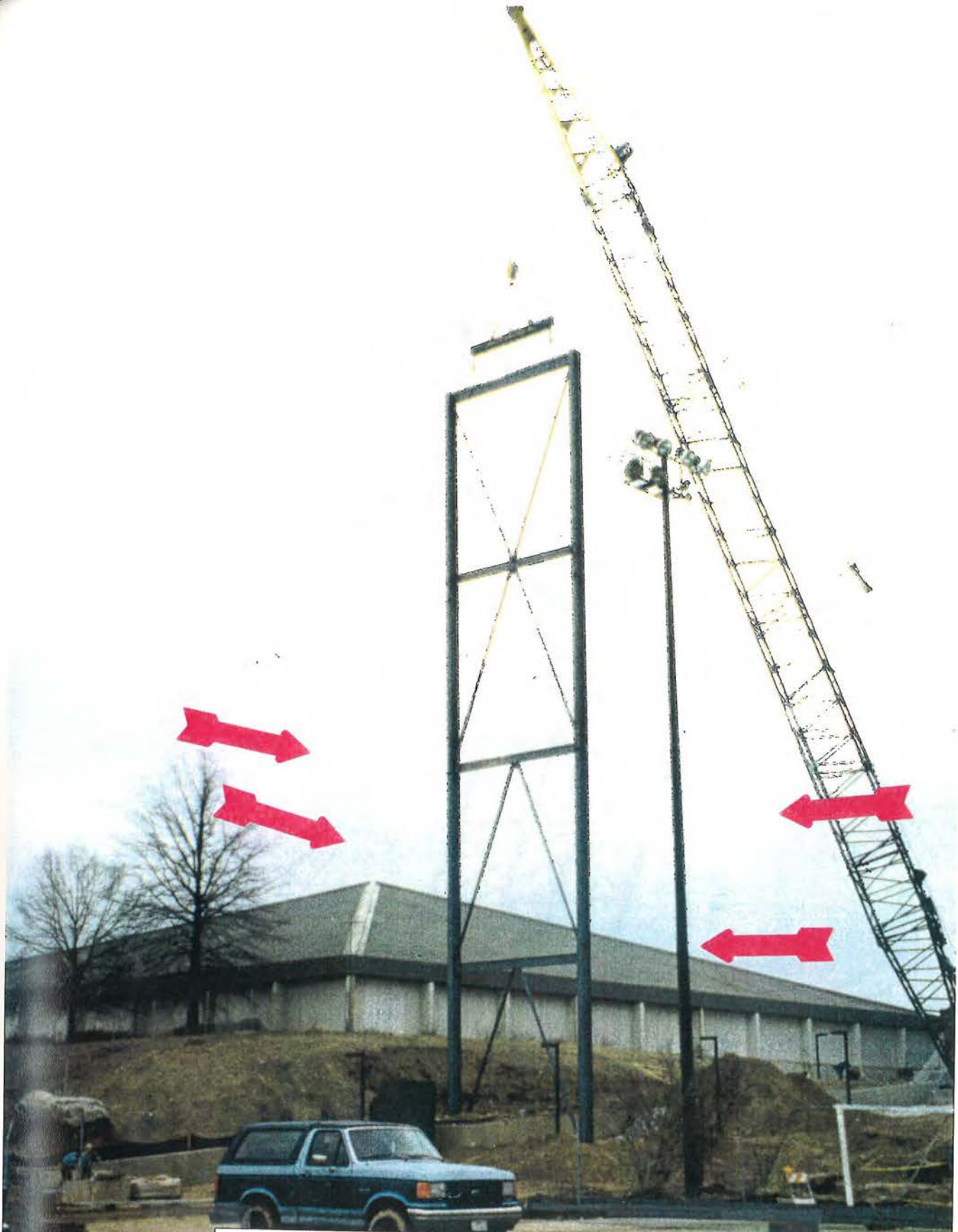

Setting Steel Frame at Column Line 11 B & C
(Arrows depict temporary guy lines)
Figure 4.1
21



Figure 4.2 - Ironworker Bolting Paired Joists (Top Chord of East Joist) to Existing Pool Structure

5. DESCRIPTION OF THE SITE AFTER THE COLLAPSE

This section discusses the site conditions after the failure. The section presents an overview of the damage caused by the collapse, detailed description of damaged components and a general description relating the physical evidence to the witness statements.

5.1 Overview of the Damage and Failed Structure

The post event site evidence showed that the failed structure had collapsed in such a manner that the paired joists appeared to have bowed near midspan and the ends of the joists translated after their connection to the supports failed. Figure 5.1 is a post event survey⁶ of the collapsed structure. The south end of the paired joists was located on top of the Student Athletic Gymnasium about 30 ft. south and 20 ft. east of its original location. The north end of the paired joists ended in a position on the ground, approximately 50 ft. south and 30 ft. west of its original location. The center of the paired joists moved about 25 ft. south and 5 ft. west. A photo montage of the failed structure is shown in Figure 5.2. Figure 5.3 shows two photographs of the failed structure with the south end resting on the Student Athletic Gymnasium. Figure 5.4 shows two photographs which include the midspan and north end of the paired joists and the position of the south deadman.

The steel frame did not completely collapse as a result of the joists failure. Column 11B deflected from its base with respect to its longitudinal axis, in a southeast direction about 20 degrees. Column 11C deflected in the same manner about one-half the deflection of 11B. Figure 5.5 shows the position of the steel frame after the collapse. The crane which was moved and rigged to the steel frame apparently to provide additional support for the structure at column 11C. This may have prevented the total collapse of the frame during the event.

All subsequent photographs show the frame lying on the ground. Due to the frame's instability after the crane was released, the frame was pulled over the day after the incident to afford safety to those needing to gain access to the incident site.

5.2 Damaged Components of the Structure

Various components of the failed structure incurred various degrees of damage or

⁶ *Location Sketch of 2 - Steel Columns and 2 - Outer Most Roof Truss Rails: 3/21/96*, Paul A. Davis, R.L.S., Midway Enterprises, Inc., Decatur, GA

displacement as a result of the failure. These components included the paired joist's main chord members, secondary members, bearing plates, anchor bolts, and welds. Additionally, a steel frame deadman was displaced from its original position.

The north steel frame deadman was displaced during the event when the steel frame deflected in the southeast direction. The 10,000 lb. deadman was pulled up a 2.5 ft. concrete retaining wall and moved laterally about 8.5 ft. Figure 5.6 shows the final location of the deadman.

The paired joists were separated from their steel support at both ends. Figures 5.7a and 5.7b show the north bearing end of the joists and Figure 5.8 shows the south end support of the joist.

Each joist is fabricated and shipped to the site in one-half sections. The joists are bolted together at center splices in the top and bottom chords after they arrive on-site. Both the top and bottom chord splices exhibited no apparent damage as a result of the failure. However, top chord members were buckled at near the center spliced location. Figure 5.9 shows the center splices and buckling in the top chord.

Visual examination revealed that many welds had failed during the event. Figure 5.10 shows fractured welds in spacers located on diagonal members between the top and bottom chords, and a spacer located between main chords of the joist. The exact locations of the fractured and/or broken welds were identified by a Testing Lab, and their impact to the integrity of the paired joists will be discussed in Structural Analysis and Discussion Chapter.

5.3 Physical Evidence Related to Witness Testimony

The physical evidence at the site appears to correlate with the eyewitnesses' testimony. The eyewitness accounts stated that the paired joists deflected downward near midspan and then bowed and rolled (top to bottom) toward the west as it fell to the ground. The structure, as it lay on the ground after the event, did appear to have failed in a crescent or bowed shape. The testimony described the steel frame deflection toward the southwest followed by the north support connection failure, with the paired joist coming off that support. The damage pattern is consistent with the eyewitnesses' statements, in that, the lateral movement of the frame would have been expected to induce forces on the north end of the paired joists which would have caused the structure to fail as-observed.

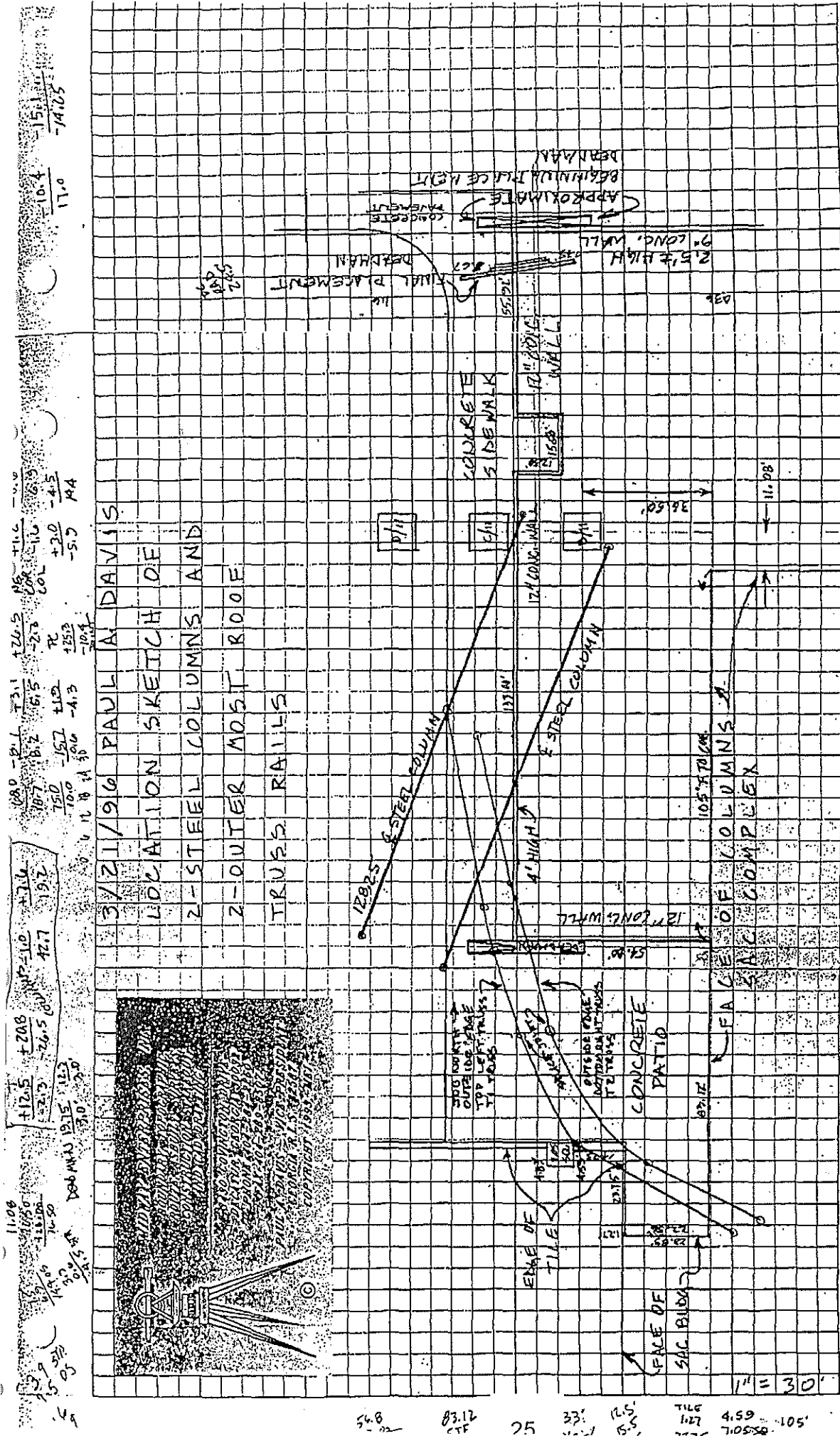

Figure 5.1 - Post Event Survey of Collapsed Structure



Figure 5.2 - Photo Montage of the Failed Structure
(Panning from Northeast to North-Northwest)



**Failed Paired Joists Resting On
Top of Gymnasium**

Top Photo (Looking East)
The Original Location of T2 Joist South
End was Directly on Top of the
Concrete Column.

Bottom Photo (Looking Southeast)
Paired Joists From South End to About
Midspan. Arrow Shows T2 Top Chord

Figure 5.3

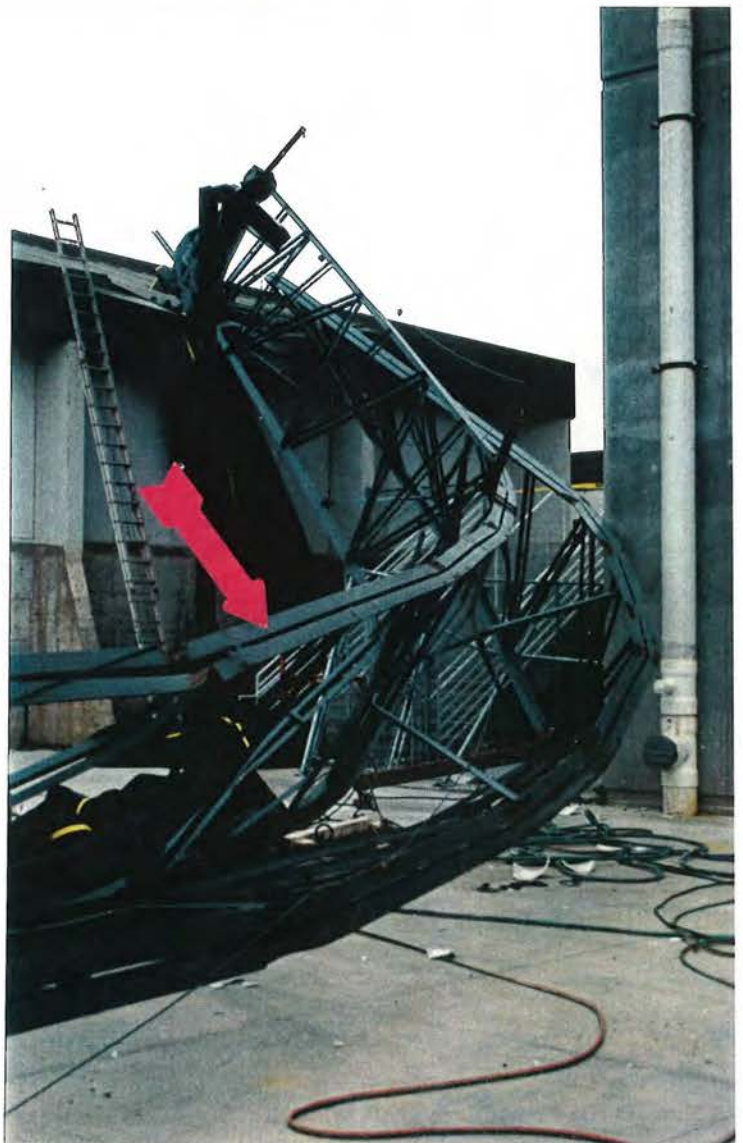

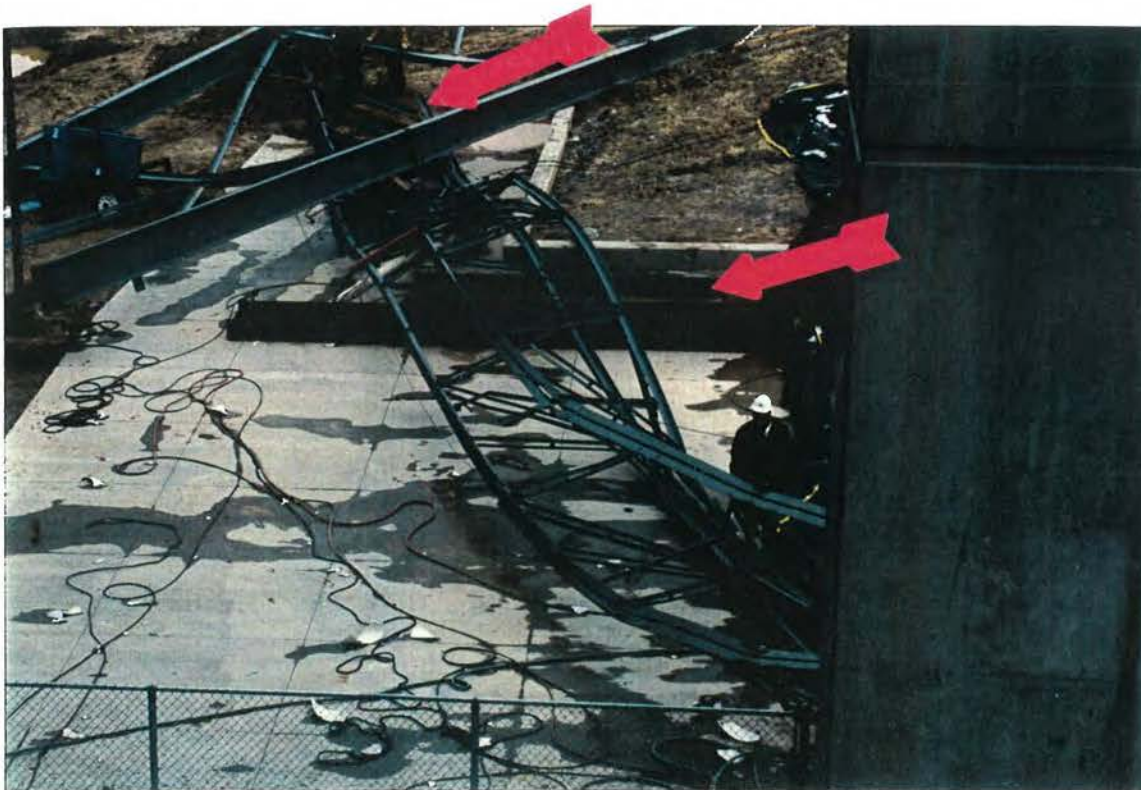

Collapsed Structure

Top Photo (Looking North-Northwest)
 North Section of the Failed Joists.
 Arrows Show North End of Paired Joists
 and South Deadman.

Note: The Steel Frame Laying Across
 the Joists Was Pulled Over After the
 Event.

Bottom Photo (Looking North)
 Midspan Section of Failed Joists
 Arrow shows T1 Top Chord.



Figure 5.4



Figure 5.5 - Post Event Disposition of Frame With Crane Hoistline Attached



North Deadman's Post Event Location
(Looking North - Arrow shows deadman)
Figure 5.6



Looking Northwest, Showing the
2 Failed Joist Bearing Connection,
T1 Joist Bearing on Left. T2 on Right.

**Failed Joists Bearing Connections
On Top of Steel Frame**

Figure 5.7a



T2 Joist Bearing. Arrow indicates location of the failed bolt.



T1 Joist Bearing. Arrow shows location of failed weld on bearing plate.

Figure 5.7b



Bearing Plate Support at South End of Failed Joists (Arrow)
(Looking - Southwest)
Figure 5.8



Top & Bottom Chord Center Splices
(Looking West - Arrow Shows Bottom Chord Splice)

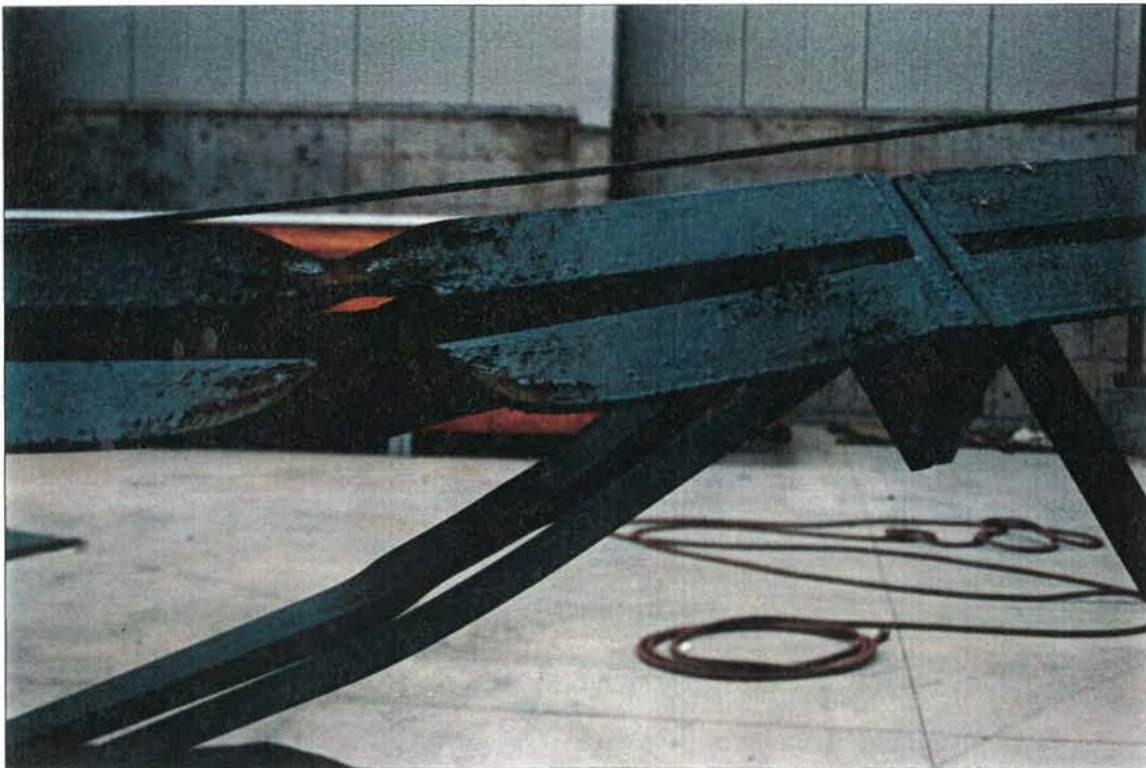

Buckling in Top Chord
(Looking West)
Figure 5.9



Fractured Welds in Diagonal Member Spacers Between Top and Bottom Chords



Fractured Weld in a Spacer Between a Joist Chord

Figure 5.10

6. STRUCTURAL ANALYSIS AND DISCUSSION

Structural analyses were performed to determine the internal member forces of the roof joists under their own dead weight and under the full design loads. These internal member forces were then compared with the limit state values to determine whether the joists could have failed due to their own weight, and to examine whether the joist members as designed were capable of supporting the maximum intended load of 210 lbs/ft. The joists were also analyzed for forces imposed on them during the hoisting/erection stage to determine whether the erection method employed by the contractor had caused any adverse effect.

A three-dimensional space frame computer model, consisting of 164 joints and 260 members, was developed for the analyses which represented the erected roof joists, marked 3T1 and 3T2, and their eight sets of diagonal bridging, see Fig. 6.1. The diagonal bridgings were assumed to have been located symmetrically with respect to the center line of the joists and have been connected to the top and bottom chords of the joists at their panel points.

The following assumptions were made for the analyses:

- o. The joists were fabricated in accordance with the shop drawings prepared by the joist manufacturer. Physical dimensions and sectional properties of the joist members used for the computer modeling were taken from the shop drawings, identified as **MARK: 3T1** and **MARK: 3T2**, provided by the joist manufacturer. See Figs. 6.2 and 6.3.
- o. The joists were sloping from the south toward the north end. Their bearing ends were placed on the steel members at the specified locations. The slopes of the joists were established as per the bearing elevations shown on the structural drawing prepared by the project structural engineer of record, see Fig. 6.4.
- o. Supporting structures at both ends of the joists were assumed to have been constructed at the intended locations and were leveled and plumbed. The support structures were not included in analyses.
- o. An erection drawing prepared by the joist manufacturer indicated that the south end bearing seat members of joists were to be connected to the permanent roof truss by high strength bolts. They were, therefore, assumed as "pinned" condition in the computer modeling. The bearing seat angles at the north end were specified to have slotted bolt holes which would allow for the joists' longitudinal movement.

They were, therefore, assumed as "roller" supports in the computer modeling. See Fig. 6.5.

- o. All joist members were assumed to be rigidly connected as they were welded at the intersecting joints. The diagonal-bridging members were, however, modeled as "pinned" at the top and bottom chords of the joists to represent their bolted connections.
- o. The 6 ft. top chord extension at the north ends of the joists were not included in the computer modeling as they did not contribute to the incident and had very little significance on the analysis.
- o. It was reported that the wind speed at or about the time of the incident was insignificant relevant to imposing any appreciable load on the structure. Therefore, wind loads were not considered in the analyses.
- o. The yield strengths of all joist members were assumed to be 50,000 PSI.

The dead weight of the joist was computed by the computer program and considered as uniformly applied member loads for all members. Based on the contract document, the total design load of the joists was specified to be 210 lbs/ft, hence, a live load of 159 lbs/ft (210 lbs/ft. - dead load = 159 lbs/ft.) was used. The live load was applied to the top chord of the joists as uniform member loads.

The erection drawing prepared by the joist manufacturer indicated different bearing details for joists T1 and T2 at their north ends. The T1 joist was to be positioned at the top of a steel wide flange beam whereas the T2 joist was to be supported on top of the steel column member, see Fig. 6.5. Due to these different support conditions, the span lengths of the two joists between the bearing ends were not identical, i.e., 177'-3/8" for T1 joist and 176'-4 3/4" for T2 joist, see Figs. 6.2 and 6.3. The length variations have been taken into consideration in modeling.

Results of the analyses are given below followed by discussion:

- (1). Under their own dead load, it was determined that the top chord of the T1 and T2 joists were subjected to an axial compressive force of 28,590 lbs. and 28,400 lbs., respectively. These forces were then compared to the maximum capacities of the top chords based upon their cross sectional properties and unbraced lengths. Both the top chords consisted of two angles 4"x4"x3/8" placed back to back at 1" apart.

Olympic Swimming Venue Structural Collapse

Of significance was the unbraced length of the top chords. Though the joists were interconnected with the bolted diagonal bridging at eight locations, the bridging lines were not anchored to any terminus point where the bridging forces could be transferred. In the absence of any viable load path for the bridging forces to be transferred and resisted, the bridging lines were considered inadequate to provide any effective translational restraint to the top chords of the joists and thus could not effectively brace the top chord.

If the unbraced length is considered to be the entire span length of the joist as discussed above, the maximum capacity was determined to be minimal, i.e. 1,440 lbs based upon the LRFD method of analysis. This capacity would be significantly increased, however, if a few of the bridging lines would be properly anchored. It was determined that if only four of the eight bridging lines were anchored, the capacity of the top chord would be increased to 32,640 lbs. It is believed that anchorage of a minimum of four bridging lines would have prevented the failure of the joists.

The following is a tabulation of the maximum internal force at the time of the collapse, and the critical strengths of the top chord members at various bracing conditions. The critical members' strengths were computed based on a Load Factor =1.0 and Resistance Factor =1.0⁷.

| Limit State Values of Top Chord Versus Actual Member Force Under Dead Weight Only. (Without the Roof Deck Attachment) | | |
|--|---|---|
| Total Number of Bridging Lines Anchored (8 Bridging Lines Installed) | Flexural-Torsional Buckling Strength as per LRFD | Actual Top Chord Member Forces due to Deadweight |
| No Bridging lines anchored | 1,440 lbs. | 28,590 lbs. |
| 4 Bridging lines anchored | 32,640 lbs. | 28,590 lbs. |
| 8 Bridging lines anchored | 71,610 lbs. | 28,590 lbs. |

⁷ *Load and Resistance Factor Design (LRFD) Specification for Structural Steel Building: 12/1/93,* American Institute of Steel Construction, Chicago, IL

- (2). It was reported that several of the spacer bars placed between the top chord angles were improperly welded. Due to the flaws in the welds, an attempt was made to determine whether the flaws contributed to the collapse. The exact locations of such spacer bars on the failed joists were identified by a testing Lab, see Fig. 6.6.- Excerpt from Report of Materials Testing and Evaluation⁸. The same Testing Lab also identified the fractured and/or broken welds of the spacer bars on the failed paired joists, see Addendum to the Report. It is stated in the Report's Addendum that "At the time of our inspection, we did not attempt to distinguish between welds that failed due to the collapse and welds that may have failed causing the collapse". (Appendix C-Lab Report and the Addendum). By eliminating all spacer bars of the above identified broken/fracture welds locations, our analyses indicated that the paired joists were capable of supporting their own dead weights if the bridging lines have been properly anchored. And It further indicated that with three consecutive spacer bars improperly welded (assumed missing in our computation), the joists would be able to support their own dead weights if the bridging lines were properly anchored.
- (3). Under the full design loads, it was determined that the top chord members would be subjected to a maximum axial force of 113,400 lbs. and 112,900 lbs. for joist T1 and T2 respectively. The bottom chord members of the joists would have a tensile force of approximately 113,500 lbs. These member forces were all within the design strength requirements of the LRFD Specifications on the premise that the roof deck would be properly attached to the top chords at every 3'-0" o.c.
- (4). The maximum deadweight deflections at the mid-span of the joists were approximately 2.066" and 2.039" for joist T1 and T2 respectively. The maximum mid-span deflection would be approximately 8.23" and 8.12" for the joists under the full design loads. See Figs. 6.7 and 6.8. The difference in the midspan deflections due to the varying overall joist lengths was insignificant and would not be a cause of failure.
- (5). The joists were hoisted at four places before being placed to their final elevation. Therefore, the joists were analyzed to determine whether the manner in which the joists were lifted contributed to the failure or not. Based on lifting locations shown in Fig. 6.9, it was concluded that the forces induced into the joists members during lifting/erecting operation were minimal and were all within the acceptable range.

⁸ Letter report from Law Engineering and Environmental Services to A. Francolini, The Whiting Turner Contracting Company - Subject: *Report of Materials Testing and Evaluation, LAW Project No. 50163-6-0144*, April 8, 1996

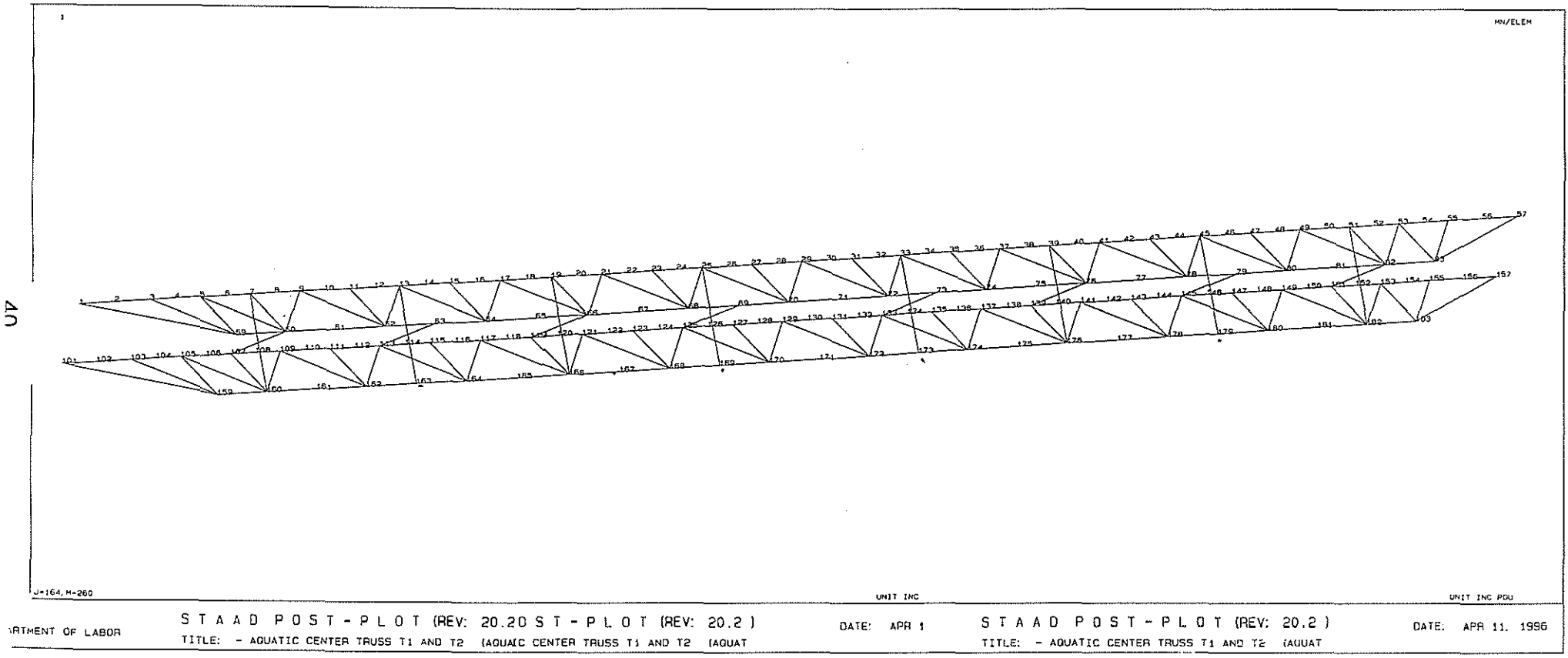

Figure 6.1 - Computer Model of the Paired Joists

VERT
REPL
WEBS

9-2 1/8

14-10 7/8

EXTL

EXTR

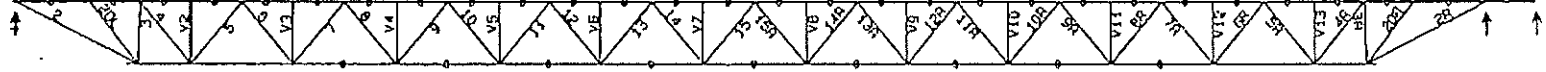

D=88 0/0

HALF
PANELS

14-9

24 @ 6-1 1/2

14-9

0-3 1/4

0-3 1/8

WORKLEN+4" = 177- 0 3/8

EXTL = 0- 2 1/8

BCXL = 1- 3 3/4

TOP CHORD 2 L 4 X 4 X .375

BOTTOM CHORD 2 L 4 X 4 X .375

EXTR = 5-10 7/8

BCXR = 1- 3 3/4

| WEB | QTY | SIZE | WELD SIZE | WEB | QTY | SIZE | WELD SIZE |
|-----|-----|----------------------|-------------|-----|-----|----------------------|-------------|
| 2 | 2* | L 3-1/2X 3-1/2X .287 | 12.1X0.224 | 15R | 2* | L 2 X 2 X .205 | 2.3X0.187 |
| 2DL | 2* | L 2 X 2 X .205 | 2.1X0.187 G | V8 | 2* | L 1-1/2X 1-1/2X .113 | 2.0X0.113 |
| 3 | 2* | L 2-1/2X 2-1/2X .188 | 5.7X0.187 | 14R | 2* | L 1-3/4X 1-3/4X .144 | 6.8X0.144 |
| 4 | 2* | L 1-3/4X 1-3/4X .188 | 7.0X0.187 | 13R | 2* | L 2 X 2 X .205 | 2.3X0.187 |
| V2 | 2* | L 1-1/2X 1-1/2X .113 | 2.0X0.113 G | V9 | 2* | L 1-1/2X 1-1/2X .113 | 2.0X0.113 |
| 5 | 2* | L 2-1/2X 2-1/2X .188 | 6.4X0.187 | 12R | 2* | L 1-3/4X 1-3/4X .144 | 6.8X0.144 |
| 6 | 2* | L 1-3/4X 1-3/4X .155 | 7.0X0.155 | 11R | 2* | L 2 X 2 X .205 | 2.7X0.187 |
| V3 | 2* | L 1-1/2X 1-1/2X .113 | 2.0X0.113 G | V10 | 2* | L 1-1/2X 1-1/2X .113 | 2.0X0.113 |
| 7 | 2* | L 2-1/2X 2-1/2X .188 | 5.2X0.187 | 10R | 2* | L 1-3/4X 1-3/4X .144 | 6.8X0.144 |
| 8 | 2* | L 1-3/4X 1-3/4X .144 | 6.8X0.144 | 9R | 2* | L 2 X 2 X .205 | 4.0X0.187 |
| V4 | 2* | L 1-1/2X 1-1/2X .113 | 2.0X0.113 | V11 | 2* | L 1-1/2X 1-1/2X .113 | 2.0X0.113 |
| 9 | 2* | L 2 X 2 X .205 | 4.0X0.187 | 8R | 2* | L 1-3/4X 1-3/4X .144 | 6.8X0.144 |
| 10 | 2* | L 1-3/4X 1-3/4X .144 | 6.8X0.144 | 7R | 2* | L 2-1/2X 2-1/2X .188 | 5.2X0.187 |
| V5 | 2* | L 1-1/2X 1-1/2X .113 | 2.0X0.113 | V12 | 2* | L 1-1/2X 1-1/2X .113 | 2.0X0.113 G |
| 11 | 2* | L 2 X 2 X .205 | 2.7X0.187 | 6R | 2* | L 1-3/4X 1-3/4X .155 | 7.0X0.155 |
| 12 | 2* | L 1-3/4X 1-3/4X .144 | 6.8X0.144 | 5R | 2* | L 2-1/2X 2-1/2X .188 | 6.4X0.187 |
| V6 | 2* | L 1-1/2X 1-1/2X .113 | 2.0X0.113 | V13 | 2* | L 1-1/2X 1-1/2X .113 | 2.0X0.113 G |
| 13 | 2* | L 2 X 2 X .205 | 2.3X0.187 | 4R | 2* | L 1-3/4X 1-3/4X .188 | 7.0X0.187 |
| 14 | 2* | L 1-3/4X 1-3/4X .144 | 6.8X0.144 | 3R | 2* | L 2-1/2X 2-1/2X .188 | 5.7X0.187 |
| V7 | 2* | L 1-1/2X 1-1/2X .113 | 2.0X0.113 | 2DR | 2* | L 2 X 2 X .205 | 2.1X0.187 G |
| 15 | 2* | L 2 X 2 X .205 | 2.3X0.187 | 2R | 2* | L 3-1/2X 3-1/2X .287 | 12.0X0.224 |

Figure 6.2 - VULCRAFT Fabrication Drawing of 3T1 Joist

VERT
REPL
WEBS

9-0 1/8

15-4 1/2

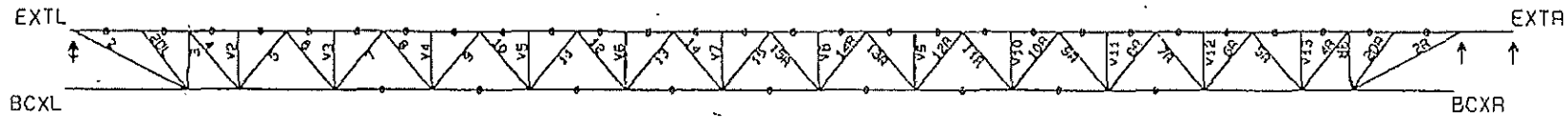

D=88 0/0

HALF
PANELS

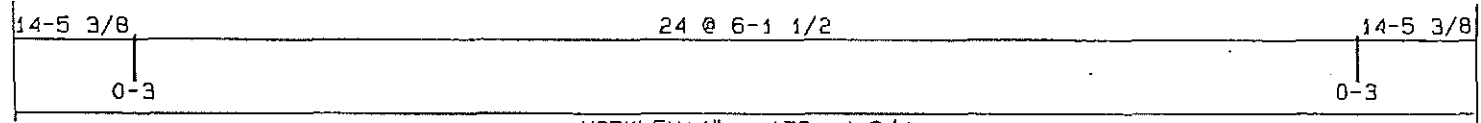

WORKLEN+4" = 176- 4 3/4

EXTL = 9- 2 1/8
BCXL = 15- 3 7/8

TOP CHORD 2 L 4 X 4 X .375
BOTTOM CHORD 2 L 4 X 4 X .375

EXTR = 6- 6 1/2
BCXR = 13- 1 1/4

| WEB | QTY | SIZE | WELD SIZE | WEB | QTY | SIZE | WELD SIZE |
|-----|-----|----------------------|-------------|-----|-----|----------------------|-------------|
| 2 | 2* | L 3-1/2X 3-1/2X .287 | 11.9X0.224 | 15R | 2* | L 2 X 2 X .205 | 2.3X0.187 |
| 2DL | 2* | L 2 X 2 X .205 | 2.2X0.187 G | V8 | 2* | L 1-1/2X 1-1/2X .113 | 2.0X0.113 |
| 3 | 2* | L 2-1/2X 2-1/2X .188 | 5.7X0.187 | 14R | 2* | L 1-3/4X 1-3/4X .144 | 6.8X0.144 |
| 4 | 2* | L 1-3/4X 1-3/4X .188 | 7.0X0.187 | 13R | 2* | L 2 X 2 X .205 | 2.3X0.187 |
| V2 | 2* | L 1-1/2X 1-1/2X .113 | 2.0X0.113 G | V9 | 2* | L 1-1/2X 1-1/2X .113 | 2.0X0.113 |
| 5 | 2* | L 2-1/2X 2-1/2X .188 | 6.4X0.187 | 12R | 2* | L 1-3/4X 1-3/4X .144 | 6.8X0.144 |
| 6 | 2* | L 1-3/4X 1-3/4X .155 | 7.0X0.155 | 11R | 2* | L 2 X 2 X .205 | 2.7X0.187 |
| V3 | 2* | L 1-1/2X 1-1/2X .113 | 2.0X0.113 G | V10 | 2* | L 1-1/2X 1-1/2X .113 | 2.0X0.113 |
| 7 | 2* | L 2-1/2X 2-1/2X .188 | 5.2X0.187 | 10R | 2* | L 1-3/4X 1-3/4X .144 | 6.8X0.144 |
| 8 | 2* | L 1-3/4X 1-3/4X .144 | 6.8X0.144 | 9R | 2* | L 2 X 2 X .205 | 4.0X0.187 |
| V4 | 2* | L 1-1/2X 1-1/2X .113 | 2.0X0.113 | V11 | 2* | L 1-1/2X 1-1/2X .113 | 2.0X0.113 |
| 9 | 2* | L 2 X 2 X .205 | 4.0X0.187 | 8R | 2* | L 1-3/4X 1-3/4X .144 | 6.8X0.144 |
| 10 | 2* | L 1-3/4X 1-3/4X .144 | 6.8X0.144 | 7R | 2* | L 2-1/2X 2-1/2X .188 | 5.2X0.187 |
| V5 | 2* | L 1-1/2X 1-1/2X .113 | 2.0X0.113 | V12 | 2* | L 1-1/2X 1-1/2X .113 | 2.0X0.113 G |
| 11 | 2* | L 2 X 2 X .205 | 2.7X0.187 | 6R | 2* | L 1-3/4X 1-3/4X .155 | 7.0X0.155 |
| 12 | 2* | L 1-3/4X 1-3/4X .144 | 6.8X0.144 | 5R | 2* | L 2-1/2X 2-1/2X .188 | 6.4X0.187 |
| V6 | 2* | L 1-1/2X 1-1/2X .113 | 2.0X0.113 | V13 | 2* | L 1-1/2X 1-1/2X .113 | 2.0X0.113 G |
| 13 | 2* | L 2 X 2 X .205 | 2.3X0.187 | 4R | 2* | L 1-3/4X 1-3/4X .188 | 7.0X0.187 |
| 14 | 2* | L 1-3/4X 1-3/4X .144 | 6.8X0.144 | 3R | 2* | L 2-1/2X 2-1/2X .188 | 5.7X0.187 |
| V7 | 2* | L 1-1/2X 1-1/2X .113 | 2.0X0.113 | 20R | 2* | L 2 X 2 X .205 | 2.2X0.187 G |
| 15 | 2* | L 2 X 2 X .205 | 2.3X0.187 | 2R | 2* | L 3-1/2X 3-1/2X .287 | 11.8X0.224 |

Figure 6.3 - VULCRAFT Fabrication Drawing of 3T2 Joist

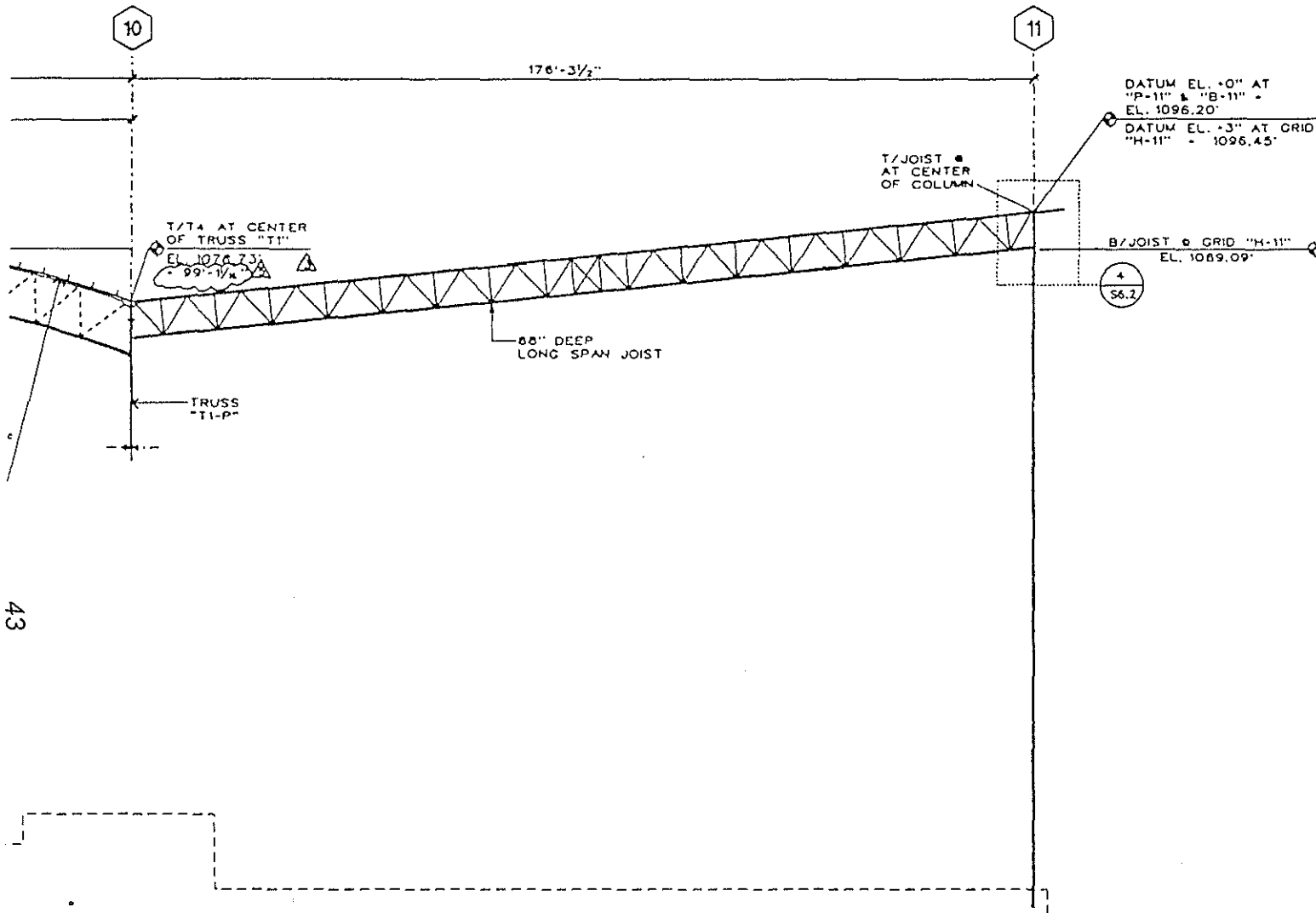

43

Figure 6.4 - Elevation Showing Sloping Joists on End Supports

OLYMPIC
AQUATIC CENTER
 GEORGIA INSTITUTE OF TECHNOLOGY
 STUDENT ATHLETIC COMPLEX
 ATLANTA, GEORGIA
 Atlanta Committee for the
 Olympic Games, Inc.

Copyright 1983 Atlanta Committee for the Olympic Games, Inc. All rights reserved. This document is the property of ACOC. The document is to be used only for the project identified herein, and is not to be used on other projects or extensions of the project, nor reproduced for any purpose, in whole or in part, except by express written authorization of ACOC. This document, and all copies thereof, shall be returned to ACOC upon completion or termination of the project, or as required by ACOC.



Stanley, Love-Stanley, P.C./
 Smallwood, Reynolds,
 Stewart, Stewart &
 Associates, Inc. A Joint Venture

Smallwood, Reynolds,
 Stewart, Stewart &
 Associates, Inc.
 One Piedmont Center, Suite 303
 3565 Piedmont Road
 Atlanta, Georgia 30305-1521
 (404) 233-5453

Stanley, Love-Stanley, P.C.
 600 W. Peachtree Street NW, Suite 1420
 Atlanta, Georgia 30308
 (404) 876-3055

Structural Engineer
 Lindsey/Harrington
 Stanley D. Lindsey & Associates, Ltd.
 2300 Windy Ridge Parkway SE
 Suite 1180 South
 Marietta, Georgia 30068
 (404) 850-1347
 Harrington Engineers, Inc.
 2981 Church Street, Suite 212
 East Point, Georgia 30344
 (404) 761-0767

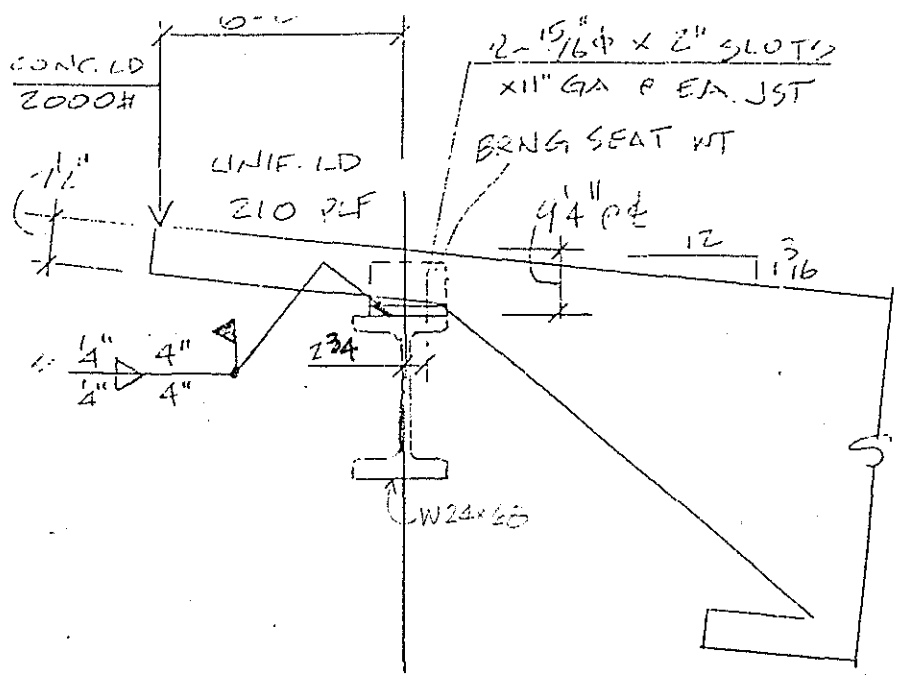
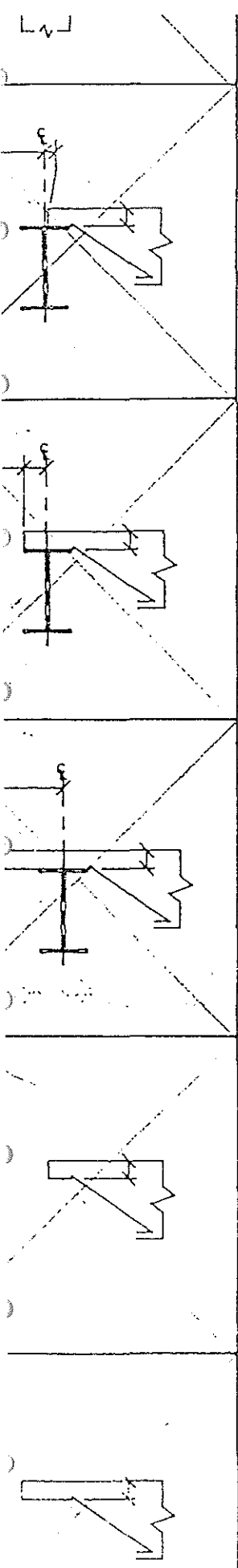

S15 BEARING DETAIL OF T1 JOIST @ NORTH END

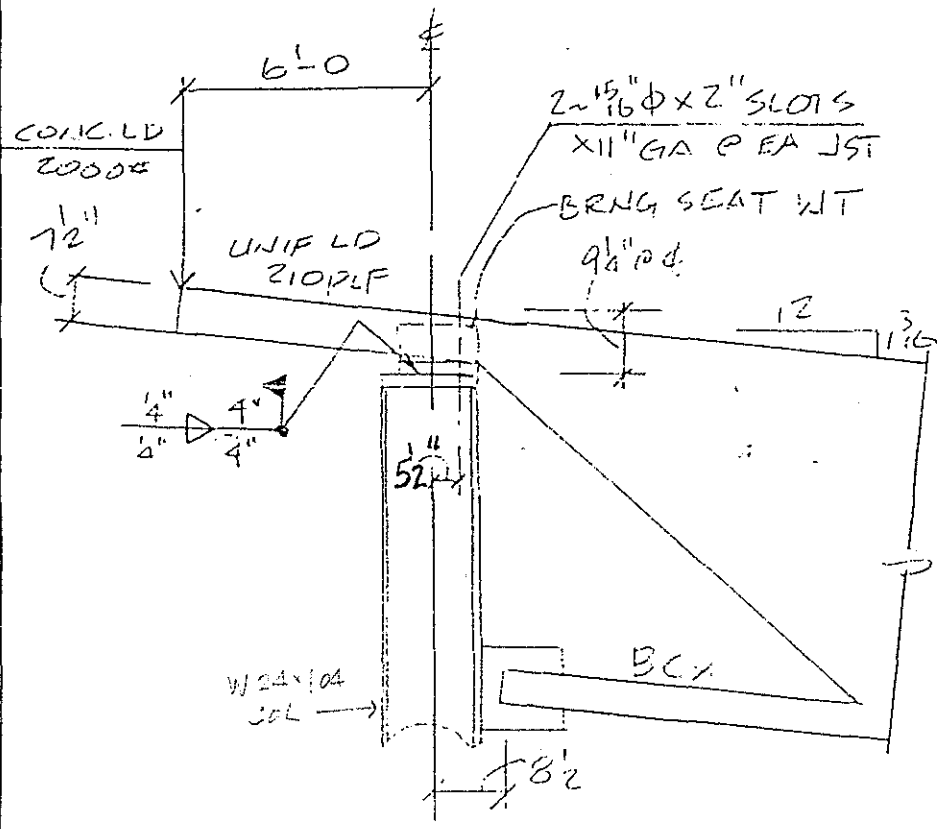

S16 BEARING DETAIL OF T2 JOIST @ NORTH END

Bearing Detail of Joist on End Supports
Figure 6.5

RESULTS

1. Steel Frame Column

All weld sizes and configurations, and members sizes were in accordance with the Owen Steel drawings.

2. Joists

All member sizes of the two failed trusses were in accordance with the shop drawings provided by Vulcraft.

The weld sizes and configurations of the two failed trusses were in accordance with the shop drawings, as modified by the facsimile transmittal from Vulcraft dated 3/27/96, except at the following locations:

| Truss | Location | Discrepancy |
|-------|-----------------------------|-------------------------|
| 3T2 | Spacer Bar at Web#3, B.C. | Undercut |
| 3T2 | Spacer Bar at Web#5, B.C. | Lack of fusion at toe |
| 3T2 | Web#2, T.C. / B.C. | Insuf. throat/Fusion |
| 3T2 | Web#11, B.C | Insufficient throat |
| 3T2 | Web#7R, B.C | Lack of fusion at toe |
| 3T2 | Spacer Bar at Web#7-8, T.C. | Missing weld, one side |
| 3T1 | Spacer Bar at Web#4, T.C. | Undercut, insuf. throat |

All of the spacer bar connections tested passed the torque test.

Post Event Identified Weld Discrepancies (Excerpt from LAW Report)
Figure 6.6

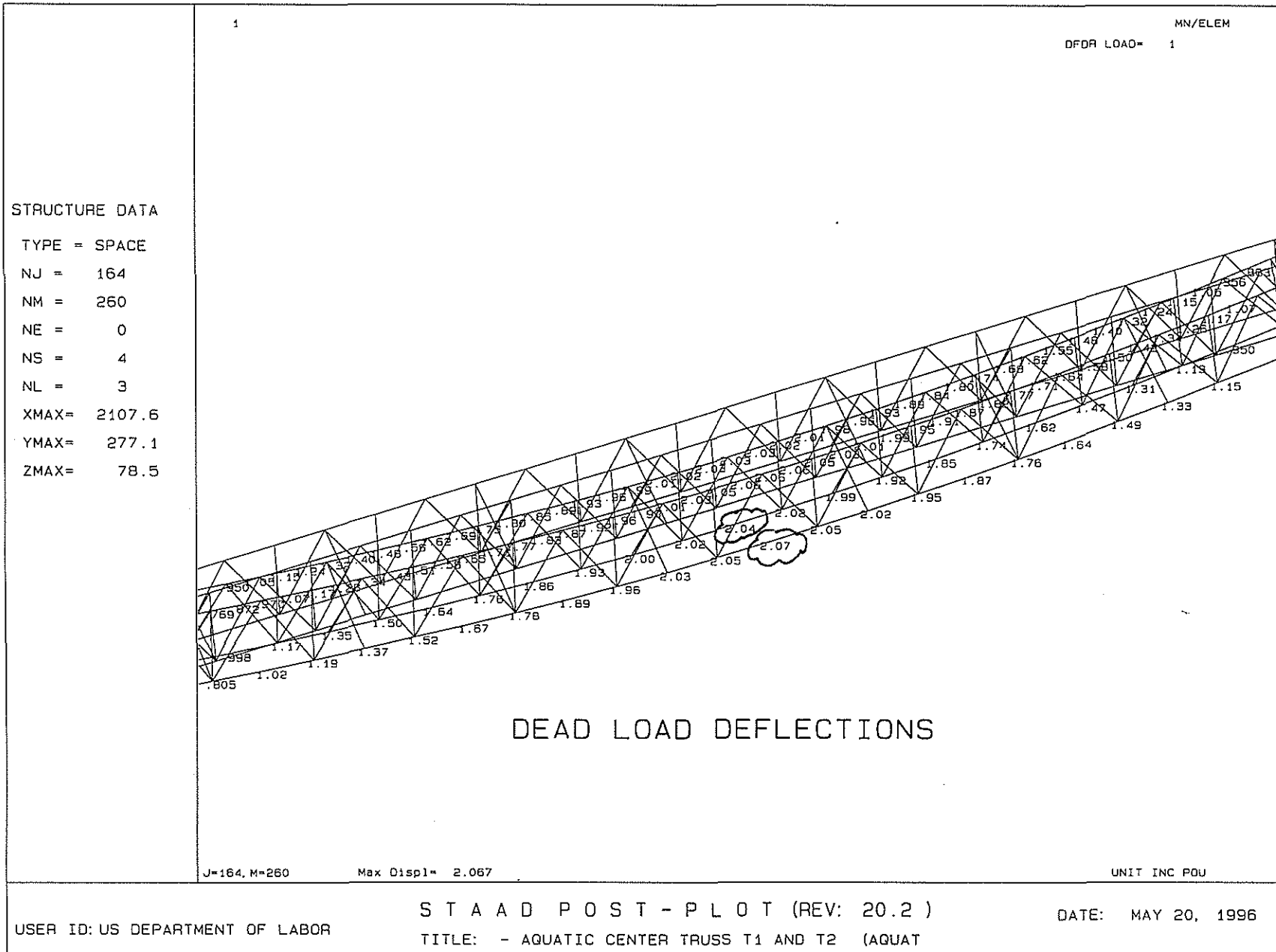

Figure 6.7 - Computer Model Showing Maximum Dead Load Deflections in the Paired Joists

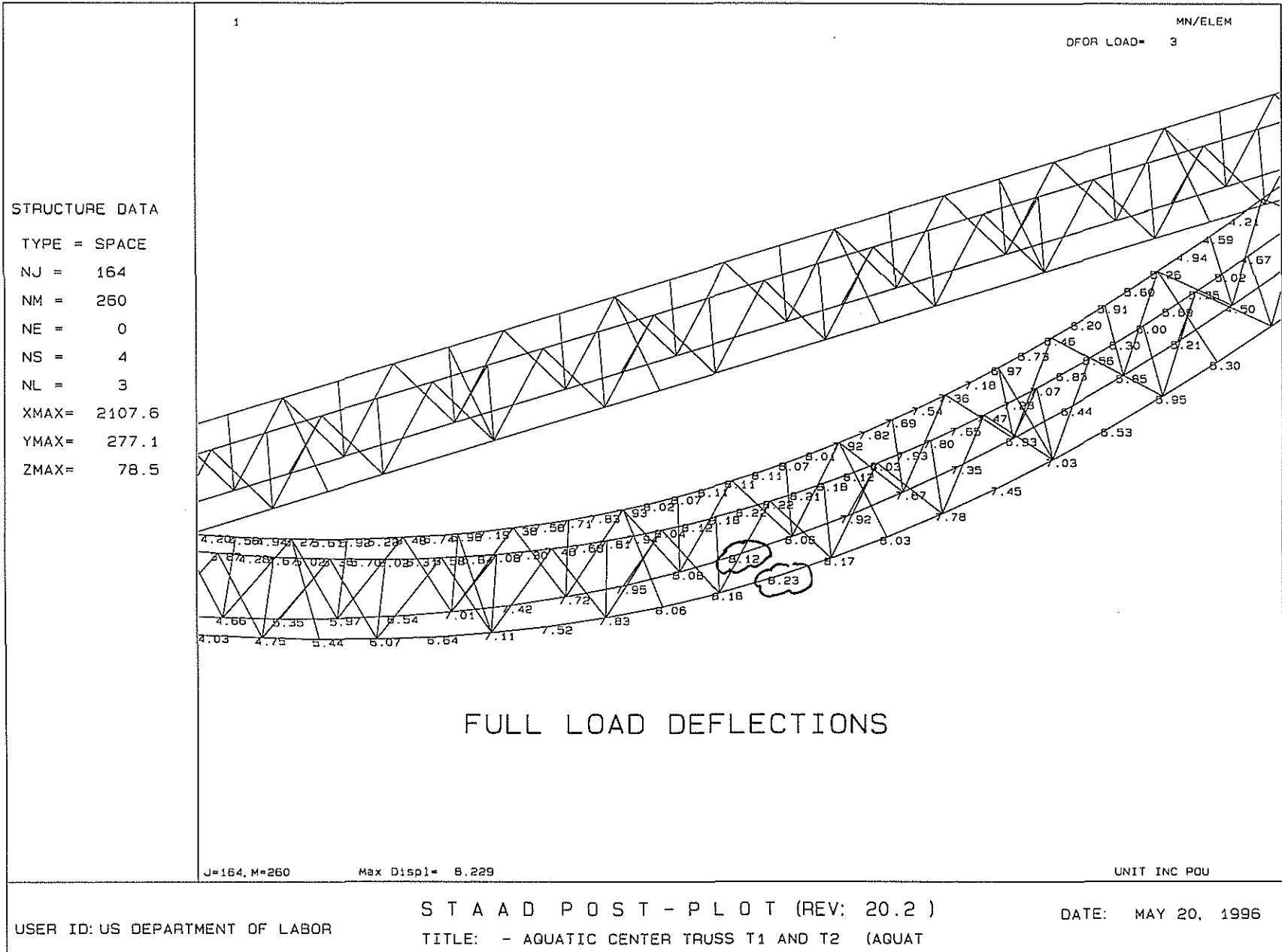

Figure 6.8 - Computer Model Showing Maximum Full Load Deflections in the Paired Joists

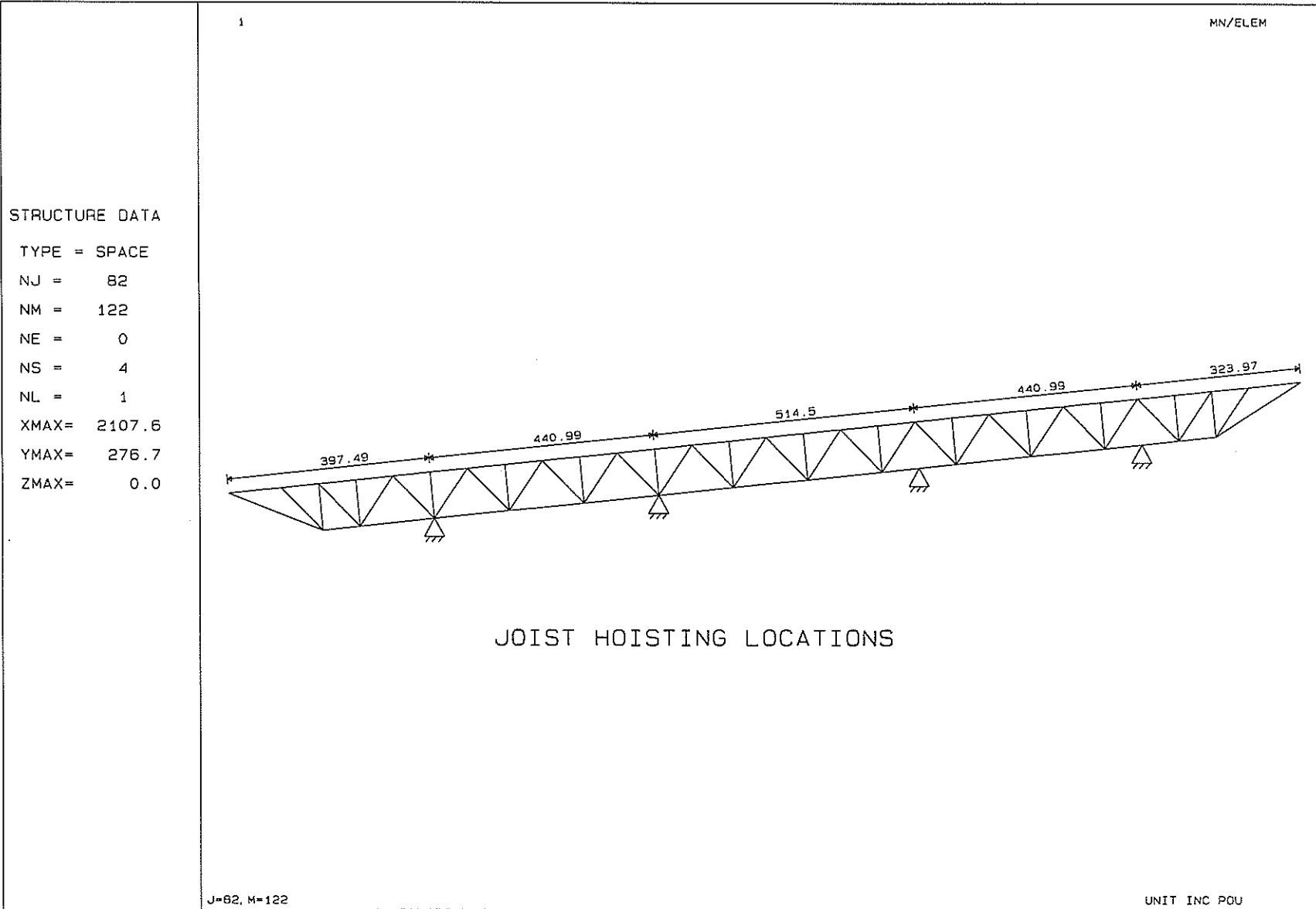

Figure 6.9 - Computer Model of the Rigging Support Points

7. OSHA STANDARDS and INDUSTRY PRACTICE

This section looks at compliance with OSHA standards and industry practice as they relate to this failure. The scope of OES involvement included the investigation of the incident including design, fabrication and erection practices. OES did not evaluate the training of personnel involved with the event. The training and other evaluations outside the OES scope of work were conducted by OSHA's AWAQ.

A specific steel erection standard, 29 CFR 1926.751(c)(2), which requires steel erection contractors to provide one center row of bolted bridging between longspans 40 or more feet in length, was deemed to be in-compliance. HELMARK did provide eight rows of bolted bridging between the joists of the 176 ft. span.

However, HELMARK did not follow industry practice with respect to anchoring all bridging lines for longspan joists. As a result the paired joists were laterally unstable and the structure failed. Appendix B contains a table which examines current and historical industry practice regarding the requirements of anchoring the joist bridging lines on longspan joists under erection. The SJI requires that all anchoring be done prior to the release of hoisting cables, see SJI's letter of June 7, 1996 in Appendix D.

To date, SJI has not adopted specifications for SLH joists. SJI does provide specifications for DLH joists which span up to 144 ft. The SLH designation is a VULCRAFT designation. SLH design principals and specifications are predicated on the specifications SJI prescribes for DLH joists⁹. VULCRAFT's application on this job required joists spans which were longer than 144 ft. Therefore, the design application called for joists which are longer than those specified by SJI. This practice if done under good engineering practice is not prohibited by SJI.

There was no written erection plan developed or used by the steel erection contractor for this job. A written erection plan is common in the industry for rigging, hoisting, and erecting structural steel which involves a critical or complex sequence of erection. The contract drawings¹⁰ state that the contractor will submit a written erection sequence to the architect engineer before beginning erection. This was not done by either SMITH-OWEN or HELMARK. According to the ironworkers, a pre-lift meeting was held to discuss the tactical operations of rigging, lifting and bolting the paired joist in-place.

⁹ Phone call from M. Marshall, OSHA to R. Pell, VULCRAFT, 5/1/96

¹⁰ *Structural Notes, Drawing Number S0.1, Structural Notes, Structural Steel, Note #10: 9/30/94, Stanley D. Lindsey, P.C.*

8. CONCLUSIONS

The following list compiles the Occupational Safety and Health Administration's conclusions related to the structural failure at the Olympic Aquatic Center:

1. The cause of the collapse was the lateral instability of the joists because of the unbraced top chords. Though the joists were provided with eight rows of diagonal bridgings they were rendered ineffective because the bridging lines were not anchored.
2. If only four out of the eight bridging lines were properly anchored, the collapse would have been prevented.
3. The joists as detailed on the shop drawings were determined to be capable of supporting the intended design loads.
4. Though there were instances of flaws in the welding of the spacer bars to the top chord of the joist, it is believed that the weld flaws did not contribute to the incident.
5. The difference in span lengths of the two joists did not contribute to the failure.
6. The steel erection contractor did not follow industry practice when they failed to anchor the bridging lines of the longspan steel joists which ultimately failed.
7. The steel supply contractor, SMITH-OWEN, did not supply a written steel erection sequence to the Architect/Structural Engineer before commencing steel erection activities. Additionally, the steel erection contractor did not develop a written steel erection plan for its activities at the site.

APPENDIX A
Computations

STRUCTURE DATA

TYPE = SPACE
 NJ = 164
 NM = 260
 NE = 0
 NS = 4
 NL = 3
 XMAX= 175.6
 YMAX= 23.1
 ZMAX= 6.5

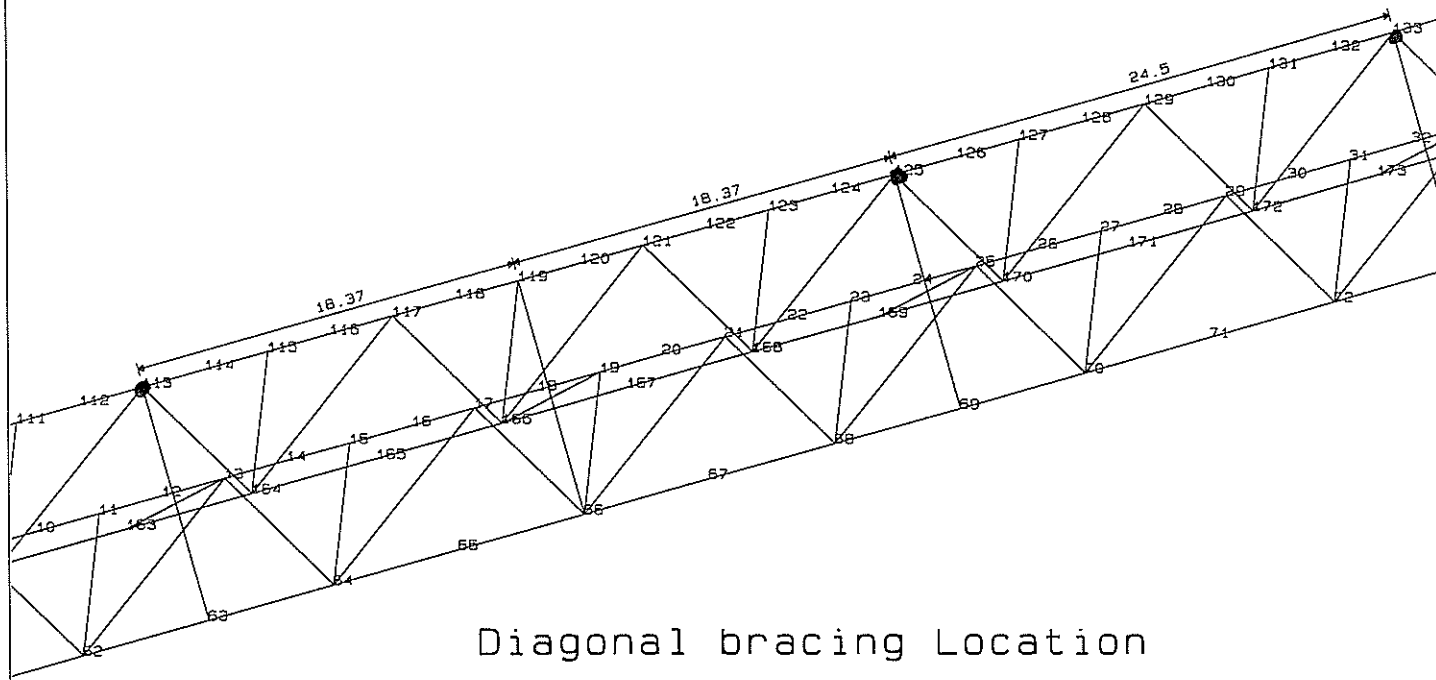

J=164, M=260

UNIT FT POU

①

STRUCTURE DATA

TYPE = SPACE
 NJ = 82
 NM = 122
 NE = 0
 NS = 2
 NL = 1
 XMAX= 2107.6
 YMAX= 276.7
 ZMAX= 0.0

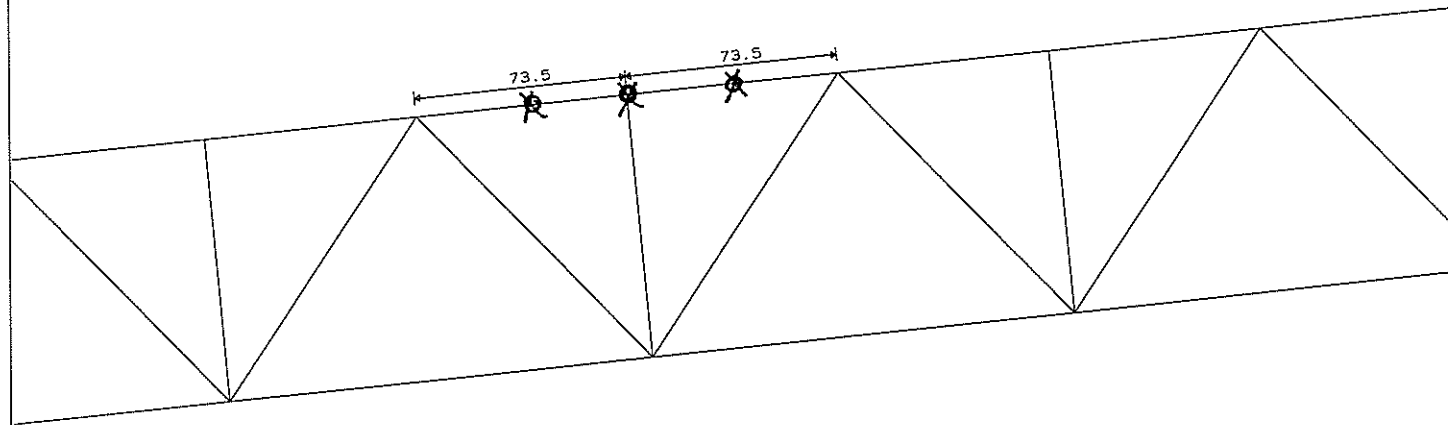

Top Chord Member Length

~~X~~ SPACER BARS NOT PRESENT

J=82, M=122

UNIT INC POU



APPENDIX B

Industry Practice Related to Anchoring Bridging

OLYMPIC AQUATIC CENTER FAILURE

Criteria Document Review (Current and Historical)

| DOCUMENT | EXCERPT(S) | COMMENTS |
|--|--|---|
| <p>1. Contract Drawings, <u>Olympic Aquatic Center, Georgia Institute of Technology Student Athletic Complex, Atlanta, Georgia, Atlanta Committee for the Olympic Games</u>. Stanley D. Lindsey, P.C., 5/18/94</p> | <p>Structural Notes, Drawing Number S0.1, "<i>General - ...4. Building code under which project...conforms to...9th Ed. Of AISC Manual...Latest Ed. Of SJI Manual</i></p> <p><i>Structural Steel - ...2. Structural steel shall be fabricated and erected according to the AISC Specification for Structural Steel Buildings...effective 1989...</i></p> <p><i>6. Open web steel joists shall be designed, fabricated and erected according to the SJI specifications...</i></p> <p><i>10. Contractor shall submit written erection sequence to Architect/Structural Engineer before beginning erection...</i></p> | <p>o Contract drawings were not provided to erector as per latest information from CSHO.</p> <p>o Standard contract document language which charges the erector with responsibility for his work, including temporary bracing, as per AISC which includes Code of Standard Practices.</p> <p>- (10) This was not done by erector.</p> |
| <p>2. <u>Field Plans for Field Use, Job - Olympic Aquatic at Atlanta, GA, File No. 27-4-390, Dwg. 2 of 2, VULCRAFT, 11/94</u></p> | <p>A. Highlighted Erectors Note, "<i>All rows of bolted erection stability bridging (EX) must be installed and connected BEFORE releasing the hoisting lines.</i></p> <p>B. Erector Notes, "<i>Longspans - 14. Hoisting cables shall not be released until ...all bolted diagonal bridging lines for spans over 100 feet are installed...</i>"</p> <p>C. VULCRAFT uses SJI Member Seal on their drawings.</p> | <p>o This document does not mention anchoring bridging lines.</p> <p>- (A) This was done by erector by erecting 2 joists with a complete set of bridging on the ground and then hoisting the unit into place.</p> <p>-(B) This was completed by erector.</p> <p>- [C] This creates a link between SJI, VULCRAFT and the erector, or in other words, this gives the erector some knowledge through the erection drawings that SJI specs are industry practice.</p> |

| DOCUMENT | EXCERPT(S) | COMMENTS |
|--|--|---|
| <p>3. Shipping Ticket (Typical) - <u>Recommendations for Handling & Erecting VULCRAFT Open Web Steel Joists</u></p> | <p>A. "4. <i>Erection must be done with plans noted "Final Plans for Field Use" and executed in accordance with latest SJI and OSHA requirements. Reference erection drawings for... any bolted erection stability erection requirements."</i></p> <p>B. "12. <i>...Field compliance with this Act (OSHA) is necessary."</i></p> | <p>o Gives erector specific industry knowledge of fabricator's recommended safe erection practices.</p> <p>o This document is does not specifically address anchoring bridging lines.</p> <p>- (A) Tells erector he must erect joist as per SJI requirements which call for both bridging <u>and anchoring</u> of bridging lines.</p> <p>- (B) Erector appears to be in-compliance with OSHA's longspan bridging only requirement 1926.752(c)(2).</p> |
| <p>4. SJI, <u>40th Edition Standard Specifications Load Tables and Weight Tables for Steel Joists and Joist Girders; K-Series, LH-Series, DLH-Series, Joist Girders</u>, Steel Joist Institute, 1994 (latest edition)</p> <p>Note: SJI DLH Series and VULCRAFT SLH Series Joists are effectively identical as per specifications, except changes is specs on member sizes are given due to the increased lengths and depths in the SLH series. SJI has not adopted any SLH specifications to date. VULCRAFT developed the SLH specifications from the LH and DLH specs as per R. Pell, VULCRAFT, Ft. Payne, AL</p> | <p>A. Pg. 53, Section 105 - <u>Erection Stability and Handling</u>, A.2.c., "<i>Where the span of the joist exceeds the erection stability span...All lines of bolted diagonal bridging are completely installed for spans over 100 feet as indicated...in the DLH Load Table.</i>"</p> <p>B. Pg. 53, Section 105 - <u>Erection Stability and Handling</u>, "C. <i>Handling - ... Each joist shall be adequately braced laterally before any loads are applied. If lateral support is provided by bridging, the bridging lines as defined in Section 105, 2(a), (b), or © must be anchored to prevent lateral movement.</i>"</p> <p>C. Pg. 53, Section 105, footnote - "<i>For a thorough coverage of this topic, refer to SJI Technical Digest #9, <u>Handling and Erection of Steel Joists and Joist Girders.</u></i>"</p> | <p>- (A) This was completed by erector.</p> <p>- (B) For this application, anchoring of the bridging lines <u>was</u> required, but not provided. SJI says before hoist cables are released, bridging and anchoring must be installed.</p> <p>- [c] This reference requires both bridging and anchoring of the bridging lines for this application. See Document #5, next page.</p> |

| DOCUMENT | EXCERPT(S) | COMMENTS |
|--|---|---|
| <p>5. SJI, SJI Technical Digest No. 9, <u>Handling and Erection of Steel Joists and Joist Girders</u>, Steel Joist Institute, 7/89</p> | <p>A. Pg. 25, Chapter V - Erection: "A. General - ... Another common characteristic of all these trusses is that, without bridging, bracing, or some other type of restraining devices, THEY ARE LATERALLY UNSTABLE."</p> <p>B. Pg. 27, "B. - Joists and Bridging: 1....Since joists are laterally unstable until bridging is properly installed, caution must be exercised during the installation process...where...4 or 5 rows of bridging are required (See Appendix A, Section 5.4), the hoisting cables shall not be released until a row of diagonal bolted bridging nearest midspan has been installed, and the bridging row has been properly anchored (See Appendix A, Section 6)."</p> <p>C. Pg. 29, "B. - Joists and Bridging: 1....It is the erector's responsibility to insure that the joist is straight lengthwise, and that it is vertically plumb... Each row of bridging must be properly anchored in order to provide the restraint required to stabilize the joist during erection. ...Progression should be from one row of bridging to the adjacent row until all rows have been installed and properly anchored."</p> <p>D. Pg. 35, "2. Longspan and Deep Longspan Joists - ...A quite common and effective practice of erection, when bolted diagonal bridging is used, is for 2 or more joists to be bridged on the ground, then hoisted onto the building...,as a unit."</p> <p>E. Pg. 53, Appendix A - "3. Section 5.5 Installation of Bridging - All bridging and bridging anchors shall be completely installed before construction loads are placed on the joists. Bridging shall support the top chords against lateral movement during the construction period and shall hold the steel joists in the approximate position as shown on the plans."</p> <p>F. Pg. 37 "2. Longspan and Deep Longspan Joists - ...Hoisting cables shall not be released until the following bolted diagonal bridging is properly installed: Span -.Over 100 feet (requires), Bolted Diagonal Bridging - All Lines."</p> | <p>- (A) Gives industry, i.e. designers, fabricators and erectors knowledge of the hazard.</p> <p>- (B) This is consistent with the other documents.</p> <p>- [c] Assigns responsibility to erector to keep joist straight, i.e. laterally stable and twice states need for anchoring bridging.</p> <p>- (D) This was practice HELMARK, erector used.</p> <p>- (E) Requires bridging & bridging anchors to provide lateral stability during erection.</p> <p>- (F) This was done, except the bridging was not anchored.</p> |

| DOCUMENT | EXCERPT(S) | COMMENTS |
|---|--|---|
| <p>5. SJI, <u>SJI Technical Digest No. 9. Handling and Erection of Steel Joists and Joist Girders</u>, Steel Joist Institute, 7/89</p> <p>(Continued)</p> | <p>G. Pg. 55, Appendix A - "6. Section 6 Handling and Erection - ...As soon as joists are erected, all bridging shall be completely installed and the joists permanently fastened into place before the application of any loads except the weight of the erectors. Many joists experience some degree of lateral instability under the weight of an erector until bridging is installed. Therefore...caution shall be exercised by the erectors until all bridging is completely and properly installed."</p> <p>H. Pg. 60, Appendix B, Longspan and Deep Longspan Specifications (1987), "6. Section 105 Handling and Erection - ...Each joist shall be adequately braced laterally before any loads are applied. If lateral support is provided by bridging, the bridging lines as defined below must be anchored to prevent lateral movement....</p> <p><i>Hoisting cables shall not be released until...all bolted diagonal bridging lines for spans over 100 feet are installed."</i></p> <p>I. Pg. 67, Appendix E, Do's & Don'ts, "...19. (DO) Securely anchor the ends of all rows of bridging."</p> | <p>- (G) "completely and properly installed" includes bridging anchors for LH, DLH & SLH joists.</p> <p>- (H) Anchorage required for LH & DLH joists.</p> <p>- (I) All bridging rows need to be anchored.</p> |

| DOCUMENT | EXCERPT(S) | COMMENTS |
|---|---|--|
| <p>6. <u>Steel Joists and Joist Girders, #5: VULCRAFT, 1995</u></p> <p>Note: Symbol on cover denotes VULCRAFT is member of SJI.</p> | <p>A. Cover "<i>Important Notice</i>", Pg. 1, "***IMPORTANT NOTICE**...THE STEEL JOIST INSTITUTE HAS DEVELOPED NEW REQUIREMENTS FOR THE USE OF ERECTION STABILITY BRIDGING...NEW SJI SPECIFICATIONS REQUIRE BOLTED DIAGONAL BRIDGING TO BE INSTALLED FOR SOME...LH SERIES JOISTS BEFORE SLACKENING THE LINES..."</p> <p>B. Pg. 72, Specification for VULCRAFT Super Longspan Steel Joists SLH-Series, "<i>204.7 Installation of Bridging - All bridging and bridging anchors shall be completely installed before construction loads are placed on the joists. Bridging shall support the top and bottom chords against lateral movement during the construction period and shall hold the steel joists in the approximate position as shown on the plans.</i>"</p> <p>C. Pg. 73, Section 205 - Handling and Erection, "<i>...Each joists shall be adequately braced laterally before any loads are applied. If lateral support is provided by bridging, the bridging lines must be anchored to prevent lateral movement....</i>"</p> <p><u>Hoisting cables shall not be released until all bridging lines are installed.</u></p> <p>D. Pg. 73, Footnote, "<i>For thorough coverage of this topic refer to SJI Technical Digest #9, <u>Handling and Erection of Steel Joists and Joist Girders.</u></i>"</p> <p>E. Pg. 119, <u>Recommended Code of Standard Practice for Steel Joists and Joist Girders</u>, "<i>...practices and customs are in accordance with good engineering practice, tend to insure safety in steel joist construction and are standard within the industry.</i>"</p> <p>F. Pg. 121, <u>Recommended Code of Standard Practice for Steel Joists and Joist Girders</u> "<i>2.5 Bridging and Bridging Anchors - Bridging standard with the manufacturer and complying with the applicable Steel Joist Institute specification of latest adoption shall be used for bridging all joists furnished by the manufacturer. Positive anchorage shall be provided at the ends of each bridging row at both the top and bottom chords.</i>"</p> <p>G. Pg. 126, <u>Recommended Code of Standard Practice for Steel Joists and Joist Girders</u>, Section 7 - Handling and Erection, "<i>...The Buyer and/or Erector shall comply with the requirements of the applicable Steel Joist Institute specification of latest adoption in the handling and erection of Material.</i>"</p> | <p>o HELMARK had a copy of this document at the time of event. They produced excerpts of it to CSHO.</p> <p>- (B) Specifically requires SLH joist to have all bridging and bridging anchors installed.</p> <p>- [c] Expressly states that if stability is provided by bridging (which it was in this case), the bridging must be anchored.</p> <p>- (E) Assigns this document as a code within the steel construction industry, including erection, as industry practice.</p> <p>- (F) Requires bridging anchorage at each row of bridging.</p> <p>- (G) Assigns erector responsibility with complying with SJI. SJI in turn requires both bridging and bridging anchors for this application.</p> |

| DOCUMENT | EXCERPT(S) | COMMENTS |
|---|--|---|
| <p>7. SJI, <u>Steel Joist Institute 60-Year Manual; A Compilation of Specifications and Load Tables 1928-1988.</u>, Steel Joist Institute, 1992</p> | <p>pg. 78, Adopted by AISC & SJI, 6/21/1962, <u>Open Web Steel Joists, LH Series</u>, "Section 205 - Handling and Erection...<i>Hoisting cables shall not be released until...two bridging lines nearest the third points of the span for spans over sixty feet are installed...</i>".</p> | <p>Although this specification has bridging requirements, it did not specifically call for anchoring the bridging lines during erection.</p> <p>Maximum listed length for LH joists was listed as 96'.</p> |
| <p>8. <u>Sources of Standards</u>, OSHA, No date</p> | <p>Pg. 167, Source document for 29 CFR 1926.751(c)(2), a.k.a. bridging requirement for longspan joists,</p> <p>Originally promulgated by State of Massachusetts (Dept. Of Labor and Industries) in 4/67.</p> <p>Adopted and promulgated by OSHA 4/17/71.</p> <p>Minor editorial change ("long span" changed to "longspan") on 5/4/72.</p> | <p>The State requirement was less restrictive than the 1962 SJI requirement for LH joists. Consequently, when OSHA adopted the standard in 1971, it too, was less restrictive than the original and current SJI requirement.</p> |
| <p>9. SJI, <u>Steel Joist Institute 60-Year Manual; A Compilation of Specifications and Load Tables 1928-1988.</u>, Steel Joist Institute, 1992</p> | <p>Pg. 111, <u>Standard Specifications for Deep Longspan Steel Joists/DLJ & DLH Series</u> adopted by SJI and AISC, 2/1/70. " <i>Section 205 Handling and Erection - ...Each joist shall be adequately braced laterally before any loads are applied. If lateral support is provided by bridging, the bridging lines as defined below must be anchored to prevent lateral movement...</i></p> <p><i>Hoisting cables shall not be released until...all bolted diagonal bridging lines for spans over 100 feet are installed.</i>"</p> <p>Pg. 142, <u>Standard Specifications for Longspan Steel Joists LJ- & LH-Series and Deep Longspan Steel Joists, DLJ- & DLH- Series</u>, adopted by AISC & SJI, 11/1/72, " <i>Section 105 Handling and Erection - ...Each joist shall be adequately braced laterally before any loads are applied. If lateral support is provided by bridging, the bridging lines as defined below must be anchored to prevent lateral movement...</i></p> <p><i>Hoisting cables shall not be released until...all bolted diagonal bridging lines for spans over 100 feet are installed.</i>"</p> | <ul style="list-style-type: none"> o The first requirements by SJI & AISC where bridging and anchoring of bridging lines is required for the DLH series. o The maximum length for DLH joists was listed as 144'. o The larger lengths and depths of the DLH joists vs. The LH series joists is the logical reason why DLH joists would require both bridging and anchoring, whereas the LH series at this time (1970) only required bridging only. o Individual LH and DLH series specifications are incorporated as one specification. o Only after the OSHA standard was promulgated did the industry advance and recognize the need to provide both bridging and anchoring of the bridging lines for not only DLH, but LH series joists. o After the original standard was promulgated, no further update of the standard has been issued by OSHA. |

| DOCUMENT | EXCERPT(S) | COMMENTS |
|--|------------|---|
| 10. Phone conversation between R. Donald Murphy, Managing Director, SJI & M. Ayub, Chief, Office of Engineering Services, OSHA 5/16/96 | | o Murphy stated SJI interprets its Longspan and Deep Longspan requirements as requiring bridging lines to be completely installed <u>and anchored</u> as specified <u>before</u> any loads such as construction loads including any erectors or dead load, i.e. the joists, is released from the hoist lines. |

APPENDIX C

Laboratory Report and Addendum



LAW

ENGINEERING AND ENVIRONMENTAL SERVICES

April 8, 1996

Mr. Andy Francolini, Operations Manager
The Whiting-Turner Contracting Company
2300 Windy Ridge Parkway
Suite 155-G
Atlanta, Georgia 30339

Subject: Report of Materials Testing and Evaluation
Georgia Tech. Aquatic Center Truss Collapse
88 SLH 210 Long Span Joists, Marks 3T1 and 3T2
Atlanta, Georgia
LAW Project No. 50163-6-0144

Dear Mr. Francolini:

Law Engineering and Environmental Services, Inc. (LAW) has completed materials testing and evaluation services related to the truss collapse on March 15, 1996. These services were provided in accordance with our proposal dated March 21, 1996 (LAW Proposal No. 563.96018). The purpose of our work was to perform the tasks outlined in the "Long-Span Joist Collapse Investigation" (Updated 03/20/96) prepared by Gaston-Thacker/Whiting-Turner (attached).

PROCEDURES

Over the past two weeks, engineers and technicians from LAW have performed inspection and testing of the steel members and welds on the joists and columns that recently collapsed at the subject project.

1. Steel Frame Column

The steel frame column involved in the collapse was surveyed to compare the as-built sizes of the members, and the length and configuration of shop and field welds, to the shop drawings prepared by Owen Steel Company Inc. The drawings provided to us for reference consisted of:

Drawings 601 and 602 as revised by 9909, 603, 605 as revised by 9908
Job No. 4-32B, Olympic Aquatic Center

2. Joists

The two long-span joists, 88 SLH 210 Marks 3T1 and 3T2, involved in the collapse were surveyed to compare the as-built sizes of the members, and the length and configuration of shop welds, to the shop drawings prepared by Vulcraft. Copies of the drawings provided to us for reference are attached. We have also attached a copy of the facsimile transmittal dated 3/27/96

LAW ENGINEERING, INC.

396 PLASTERS AVENUE, N.E. • ATLANTA, GA 30324
(404) 873-4761 • FAX (404) 881-0508

ONE OF THE LAW COMPANIES

from Mr. Mark Miller modifying the configuration of the spacer bar weld specified. During our inspection, the appearance of the welds were compared to the requirements of Section 203.5 for SLH-Series Joists in *Steel Joists and Joist Girders* by Vulcraft.

During the survey, we performed a "torque test" at each of the chord spacer bars of the failed trusses and of 11 additional trusses being stored at the site. The purpose of this torque test was to proof test the spacer bar connections to the reported design strength of 2,300 pounds. A copy of the spacer bar design load calculations was provided in a facsimile transmittal dated 03/26/96 from Mr. Randy G. Pell of Vulcraft (attached).

A torque test was developed for use instead of the "pry bar" test, since measuring the applied load with a torque wrench was preferred compared to using a pry bar. For the torque test, a hexagon-shaped bar with 0.6-inch flats was inserted in between the chord members at each spacer bar. Where required, shim plates were used to snug the bar between the chords. A torque wrench was used to apply 115 foot-pounds. Connections that did not fail by fracture or cracking of the weld during application of the torque load were considered passing.

3. Laboratory Testing

After the visual survey, three portions of joist chords including spacer bars were selected for tensile testing. The approximate locations of the samples are indicated on the attached Vulcraft drawings. The chords samples approximately 24 inches long, roughly centered about the spacer bar. The samples were tested in tension to determine ultimate load as schematically shown in Figure One (attached).

Selected portions of the top chord, bottom chord and web members of the failed joists were selected by LAW for laboratory testing. The approximate locations of the samples are indicated on the attached Vulcraft drawings. The samples were selected at locations at least 12 inches away from apparent damage or distortion caused by the collapse and are indicated on the attached drawings. After cutting, the samples were taken to our laboratory for machining into standard tensile specimens. These specimens were tested in accordance with ASTM A 370, *Standard Test Methods and Definitions for Mechanical Testing of Steel Products*

4. Review of Footing Construction Observations

We have reviewed our field construction reports regarding inspection of the subsurface soils and reinforcing bar placement within the footings associated with the collapse prior to concrete placement. We have also reviewed the results of compressive strength testing of cylinders obtained during concrete placement. Since specific records regarding footing locations were not made during concrete sampling, we could not determine the actual results of these footings. However, we did review all of our test results for footing concrete.

RESULTS

1. Steel Frame Column

All weld sizes and configurations, and members sizes were in accordance with the Owen Steel drawings.

2. Joists

All member sizes of the two failed trusses were in accordance with the shop drawings provided by Vulcraft.

The weld sizes and configurations of the two failed trusses were in accordance with the shop drawings, as modified by the facsimile transmittal from Vulcraft dated 3/27/96, except at the following locations:

| Truss | Location | Discrepancy |
|-------|-----------------------------|-------------------------|
| 3T2 | Spacer Bar at Web#3, B.C. | Undercut |
| 3T2 | Spacer Bar at Web#5, B.C. | Lack of fusion at toe |
| 3T2 | Web#2, T.C. / B.C. | Insuf. throat/Fusion |
| 3T2 | Web#11, B.C | Insufficient throat |
| 3T2 | Web#7R, B.C | Lack of fusion at toe |
| 3T2 | Spacer Bar at Web#7-8, T.C. | Missing weld, one side |
| 3T1 | Spacer Bar at Web#4, T.C. | Undercut, insuf. throat |

All of the spacer bar connections tested passed the torque test.

3. Laboratory Testing

The following table summarizes the results of the spacer bar connection tensile testing:

| Truss | Ultimate Tensile Strength (lbs.) | Minimum Design Strength ¹ (lbs.) |
|---------------------|----------------------------------|---|
| 3T1L #1, Top Chord | 34,100 | 2,300 |
| 3T1R #2, Top Chord | 25,600 | 2,300 |
| 3T2L #1, Bot. Chord | 33,200 | 2,300 |

NOTE 1: The reported minimum design strength was provided by Vulcraft.

The tensile test results of the samples obtained from the top chord, bottom chord and web members met the requirements of both ASTM standards that Vulcraft references:

ASTM A 529-92, Standard Specification for High-Strength Carbon-Manganese Steel of Structural Quality, Grade 50

ASTM A 572-88, Standard Specification for High-Strength Low-Alloy Columbium-Vanadium Steels of Structural Quality, Grade 50

Table One (attached) presents the details of the tensile test results.

4. Review of Footing Construction Observations

The bearing capacity of the footing was evaluated by an engineer from LAW prior to footing construction and was determined to be acceptable. Placement of reinforcing bars in the footing was not inspected by LAW. While LAW and Gaston-Thacker/Whiting-Turner representatives obtained cylinders at the site during concrete placement in footings, actual footing locations were only provided on one occasion during sampling (Footings B and E on line 11). Based on our review of the drawings, Footing B-11 was supporting one column of the support frame that collapsed. The 7-day compressive strength of the cylinder tested was 3,070 psi.

We have reviewed the compressive strength results of all tests performed to date. While only 7-day tests are available at this time, it appears that all of the concrete samples will exceed the specified 28-day compressive strength of 4,000 psi. We have attached copies of the Concrete Test Reports that have been issued to date. Completed 28-day test results will be available next week.

The Whiting-Turner Contracting Company
April 8, 1996
Page 5

CLOSING

We have appreciated serving as your materials engineering consultant on this project. If you have any questions concerning this report, please contact us.

Sincerely,

LAW ENGINEERING AND ENVIRONMENTAL SERVICES, INC.

Timothy A. Ozell, P.E.
Principal Engineer

Darron V. Edens
Staff Engineer

Attachments: Long-Span Joist Collapse Investigation outline
Vulcraft Shop Drawings
Vulcraft Spacer Bar Weld Re-Configuration
Vulcraft Spacer Bar Calculations
Figure One
Table One
Concrete Test Reports (3)

Long-Span Joist Collapse Investigation Outline

| # | INVESTIGATION OF: | ACTION ITEM: | ACOG | OTMT | Owen | Vukobrat | Helmark | Law | SRSS & S-L-S | Underway & Harsh | Findings: (C or NS) | Date to Complete |
|----|---------------------|--|------|------|------|----------|---------|-----|--------------|------------------|---------------------|------------------|
| 1 | JOISTS | Check joist shop drawings for compliance to Contract Documents | x | x | x | XX | | | x | XX | | 02/22/96 |
| 2 | | Check joist fabrication for compliance to <u>Shop Drawings</u> (including field inspection of welds) | x | x | x | XX | | XX | x | x | | 3 02/22/96 |
| 3 | | Obtain Mill Certifications | | | | XX | | | | | | 02/22/96 |
| 4 | | Obtain a test plug of steel & test for strength | | | | | | XX | | | | 02/22/96 |
| 5 | | Investigate "bowing" of joists & QC & damage of diagonals (joists that not yet have been erected) | | | | XX | | x | | x | | 02/22/96 |
| 6 | | Obtain QC inspection reports from shop | | | | XX | | | | | | 02/22/96 |
| 7 | | Check welds on spacers & determine structural value to system | | | | XX | | XX | | XX | Welded | 02/22/96 |
| 8 | | Provide design calculations & review | | | | XX | | | | XX | | 02/22/96 |
| 9 | STEEL COLUMNS | Check shop drawings for compliance to Contract Documents | x | x | XX | | | | x | XX | | 02/22/96 |
| 10 | | Check fabrication for compliance to <u>Shop Drawings</u> | x | x | XX | | | XX | x | XX | | 02/22/96 |
| 11 | | Obtain Mill Certifications | | | XX | | | | | | | 02/22/96 |
| 12 | | Check shop & field welds | x | x | x | | | XX | x | x | | 02/22/96 |
| 13 | FOUNDATIONS | Verify the use of the proper mix design | | XX | | | | | | | | 02/21/96 |
| 14 | | Obtain test breaks of cylinders | | | | | | XX | | | | 02/21/96 |
| 15 | | Review field reports for rebar & anchor bolt placement | | | | | | XX | | | | 02/21/96 |
| 16 | | Survey foundation for possible movement from as-built location | | XX | | | | | | | | 02/21/96 |
| 17 | ERECTION PROCEDURES | Review all calculations for stabilizing tower | | | x | | XX | | | x | | 02/22/96 |
| 18 | | Review all calculations for stabilizing joists | | | x | XX | XX | | | x | | 02/22/96 |
| 19 | STRUCTURAL DESIGN | Re-check all structural design calculations of steel tower (including review by an independent engineer) | | | | | | | x | XX | | 02/22/96 |
| 20 | | Re-check all design calculations for foundations | | | | | | | x | XX | | 02/22/96 |
| 21 | | Re-check assumptions made for specifying joists | | | | | | | x | XX | | 02/22/96 |
| 22 | | | | | | | | | | | | |
| 23 | | | | | | | | | | | | |
| 24 | | | | | | | | | | | | |
| 25 | | | | | | | | | | | | |

XX Primary responsible party x Secondary responsible party

01/27/1994 16:40 409/249505

UFW

Vulcraft Shop Drawings

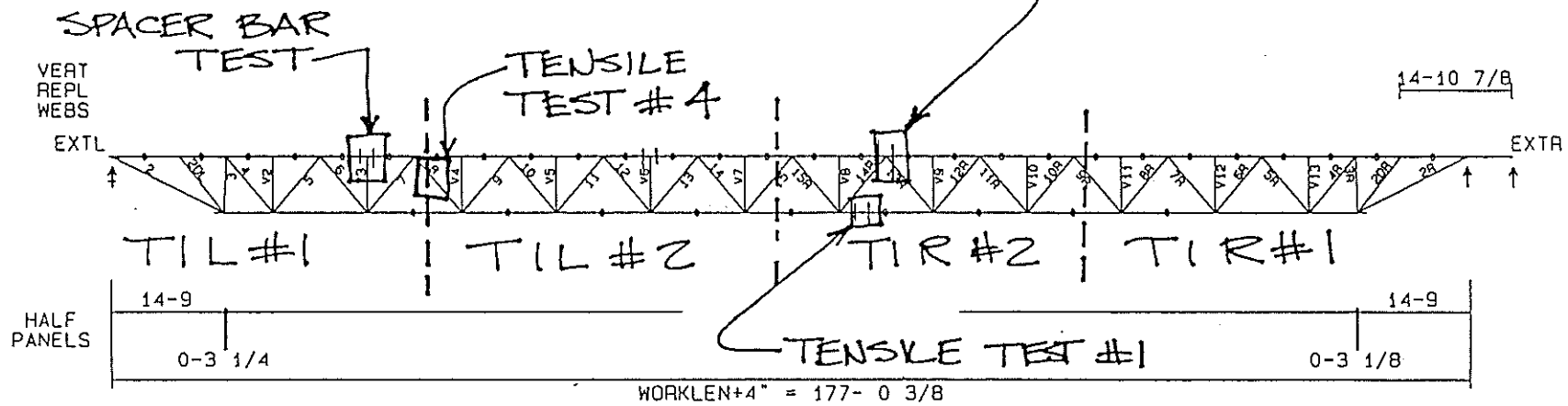

EXTL = 0- 2 1/8
 BCXL = 1- 3 3/4

TOP CHORD 2 L 4 X 4 X .375
 BOTTOM CHORD 2 L 4 X 4 X .375

EXTRA = 5-10 7/8
 BCXA = 1- 3 3/4

| WEB | QTY | SIZE | WELD SIZE | WEB | QTY | SIZE | WELD SIZE |
|-----|-----|----------------------|-------------|-----|-----|----------------------|-------------|
| 2 | 2* | L 3-1/2X 3-1/2X .287 | 12.1X0.224 | 15R | 2* | L 2 X 2 X .205 | 2.3X0.187 |
| 2DL | 2* | L 2 X 2 X .205 | 2.1X0.187 G | V8 | 2* | L 1-1/2X 1-1/2X .113 | 2.0X0.113 |
| 3 | 2* | L 2-1/2X 2-1/2X .188 | 5.7X0.187 | 14R | 2* | L 1-3/4X 1-3/4X .144 | 6.8X0.144 |
| 4 | 2* | L 1-3/4X 1-3/4X .188 | 7.0X0.187 | 13R | 2* | L 2 X 2 X .205 | 2.3X0.187 |
| V2 | 2* | L 1-1/2X 1-1/2X .113 | 2.0X0.113 G | V9 | 2* | L 1-1/2X 1-1/2X .113 | 2.0X0.113 |
| 5 | 2* | L 2-1/2X 2-1/2X .188 | 6.4X0.187 | 12R | 2* | L 1-3/4X 1-3/4X .144 | 6.8X0.144 |
| 6 | 2* | L 1-3/4X 1-3/4X .155 | 7.0X0.155 | 11R | 2* | L 2 X 2 X .205 | 2.7X0.187 |
| V3 | 2* | L 1-1/2X 1-1/2X .113 | 2.0X0.113 G | V10 | 2* | L 1-1/2X 1-1/2X .113 | 2.0X0.113 |
| 7 | 2* | L 2-1/2X 2-1/2X .188 | 5.2X0.187 | 10R | 2* | L 1-3/4X 1-3/4X .144 | 6.8X0.144 |
| 8 | 2* | L 1-3/4X 1-3/4X .144 | 6.8X0.144 | 9R | 2* | L 2 X 2 X .205 | 4.0X0.187 |
| V4 | 2* | L 1-1/2X 1-1/2X .113 | 2.0X0.113 | V11 | 2* | L 1-1/2X 1-1/2X .113 | 2.0X0.113 |
| 9 | 2* | L 2 X 2 X .205 | 4.0X0.187 | 8R | 2* | L 1-3/4X 1-3/4X .144 | 6.8X0.144 |
| 10 | 2* | L 1-3/4X 1-3/4X .144 | 6.8X0.144 | 7R | 2* | L 2-1/2X 2-1/2X .188 | 5.2X0.187 |
| V5 | 2* | L 1-1/2X 1-1/2X .113 | 2.0X0.113 | V12 | 2* | L 1-1/2X 1-1/2X .113 | 2.0X0.113 G |
| 11 | 2* | L 2 X 2 X .205 | 2.7X0.187 | 6R | 2* | L 1-3/4X 1-3/4X .155 | 7.0X0.155 |
| 12 | 2* | L 1-3/4X 1-3/4X .144 | 6.8X0.144 | 5R | 2* | L 2-1/2X 2-1/2X .188 | 6.4X0.187 |
| V6 | 2* | L 1-1/2X 1-1/2X .113 | 2.0X0.113 | V13 | 2* | L 1-1/2X 1-1/2X .113 | 2.0X0.113 G |
| 13 | 2* | L 2 X 2 X .205 | 2.3X0.187 | 4R | 2* | L 1-3/4X 1-3/4X .188 | 7.0X0.187 |
| 14 | 2* | L 1-3/4X 1-3/4X .144 | 6.8X0.144 | 3R | 2* | L 2-1/2X 2-1/2X .188 | 5.7X0.187 |
| V7 | 2* | L 1-1/2X 1-1/2X .113 | 2.0X0.113 | 2DR | 2* | L 2 X 2 X .205 | 2.1X0.187 G |
| 15 | 2* | L 2 X 2 X .205 | 2.3X0.187 | 2R | 2* | L 3-1/2X 3-1/2X .287 | 12.0X0.224 |

MARK: 3T1 88SLH210 27-4- 390 L105 OLYMPIC AQUATIC THU, MAR 21 1996 15:04:35 RGP

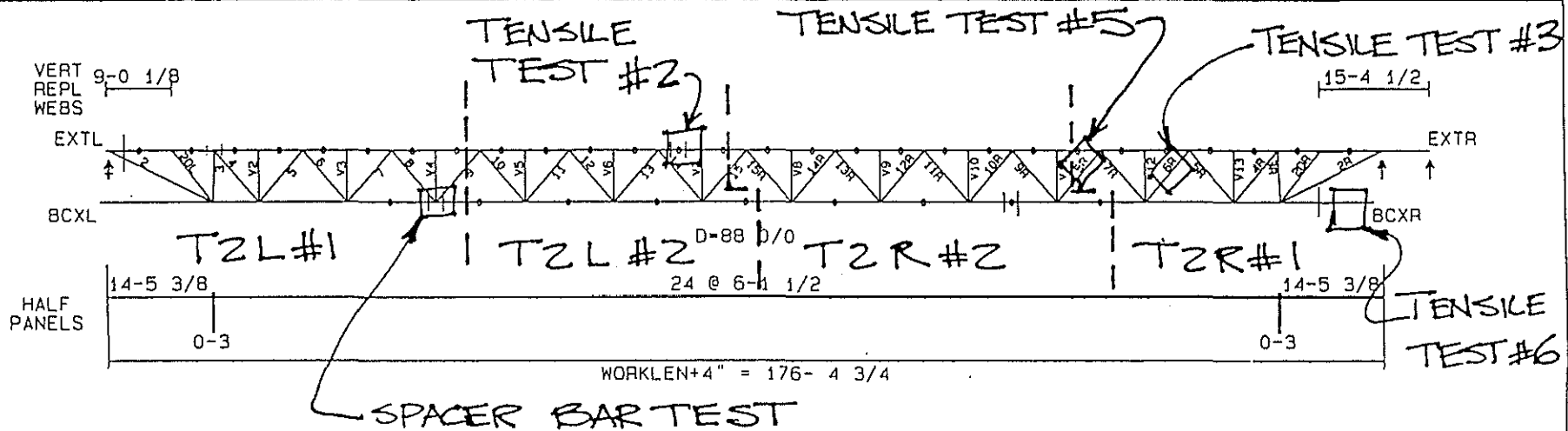

EXTL = 0- 2 1/8
 BCXL = 15- 3 7/8

TOP CHORD 2 L 4 X 4 X .375
 BOTTOM CHORD 2 L 4 X 4 X .375

EXTR = 6- 6 1/2
 BCXR = 13- 1 1/4

| WEB | QTY | SIZE | WELD SIZE | WEB | QTY | SIZE | WELD SIZE |
|-----|-----|----------------------|-------------|-----|-----|----------------------|-------------|
| 2 | 2* | L 3-1/2X 3-1/2X .287 | 11.9X0.224 | 15R | 2* | L 2 X 2 X .205 | 2.3X0.187 |
| 2DL | 2* | L 2 X 2 X .205 | 2.2X0.187 G | V8 | 2* | L 1-1/2X 1-1/2X .113 | 2.0X0.113 |
| 3 | 2* | L 2-1/2X 2-1/2X .188 | 5.7X0.187 | 14R | 2* | L 1-3/4X 1-3/4X .144 | 6.8X0.144 |
| 4 | 2* | L 1-3/4X 1-3/4X .188 | 7.0X0.187 | 13R | 2* | L 2 X 2 X .205 | 2.3X0.187 |
| V2 | 2* | L 1-1/2X 1-1/2X .113 | 2.0X0.113 G | V9 | 2* | L 1-1/2X 1-1/2X .113 | 2.0X0.113 |
| 5 | 2* | L 2-1/2X 2-1/2X .188 | 6.4X0.187 | 12R | 2* | L 1-3/4X 1-3/4X .144 | 6.8X0.144 |
| 6 | 2* | L 1-3/4X 1-3/4X .155 | 7.0X0.155 | 11R | 2* | L 2 X 2 X .205 | 2.7X0.187 |
| V3 | 2* | L 1-1/2X 1-1/2X .113 | 2.0X0.113 G | V10 | 2* | L 1-1/2X 1-1/2X .113 | 2.0X0.113 |
| 7 | 2* | L 2-1/2X 2-1/2X .188 | 5.2X0.187 | 10R | 2* | L 1-3/4X 1-3/4X .144 | 6.8X0.144 |
| 8 | 2* | L 1-3/4X 1-3/4X .144 | 6.8X0.144 | 9R | 2* | L 2 X 2 X .205 | 4.0X0.187 |
| V4 | 2* | L 1-1/2X 1-1/2X .113 | 2.0X0.113 | V11 | 2* | L 1-1/2X 1-1/2X .113 | 2.0X0.113 |
| 9 | 2* | L 2 X 2 X .205 | 4.0X0.187 | 8R | 2* | L 1-3/4X 1-3/4X .144 | 6.8X0.144 |
| 10 | 2* | L 1-3/4X 1-3/4X .144 | 6.8X0.144 | 7R | 2* | L 2-1/2X 2-1/2X .188 | 5.2X0.187 |
| V5 | 2* | L 1-1/2X 1-1/2X .113 | 2.0X0.113 | V12 | 2* | L 1-1/2X 1-1/2X .113 | 2.0X0.113 G |
| 11 | 2* | L 2 X 2 X .205 | 2.7X0.187 | 6R | 2* | L 1-3/4X 1-3/4X .155 | 7.0X0.155 |
| 12 | 2* | L 1-3/4X 1-3/4X .144 | 6.8X0.144 | 5R | 2* | L 2-1/2X 2-1/2X .188 | 6.4X0.187 |
| V6 | 2* | L 1-1/2X 1-1/2X .113 | 2.0X0.113 | V13 | 2* | L 1-1/2X 1-1/2X .113 | 2.0X0.113 G |
| 13 | 2* | L 2 X 2 X .205 | 2.3X0.187 | 4R | 2* | L 1-3/4X 1-3/4X .188 | 7.0X0.187 |
| 14 | 2* | L 1-3/4X 1-3/4X .144 | 6.8X0.144 | 3R | 2* | L 2-1/2X 2-1/2X .188 | 5.7X0.187 |
| V7 | 2* | L 1-1/2X 1-1/2X .113 | 2.0X0.113 | 2DR | 2* | L 2 X 2 X .205 | 2.2X0.187 G |
| 15 | 2* | L 2 X 2 X .205 | 2.3X0.187 | 2R | 2* | L 3-1/2X 3-1/2X .287 | 11.8X0.224 |

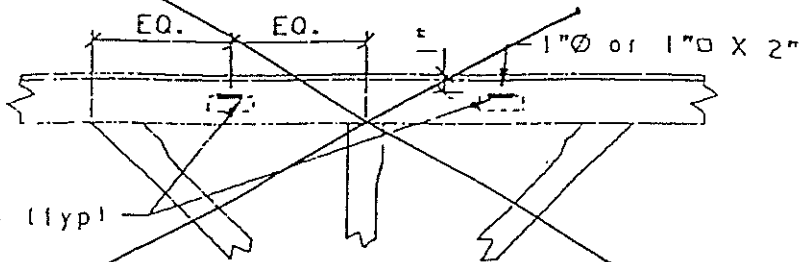

$\frac{3}{8} \times \frac{1}{2}$ " weld (typ)

Plug applies to $2\frac{1}{2}$ " and smaller chords.

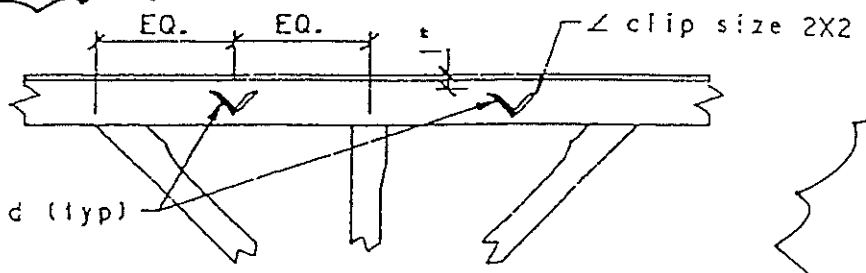

$\frac{3}{8} \times 1\frac{1}{2}$ " weld (typ)

Stitch applies to $3\frac{1}{2}$ " to 4" chords.

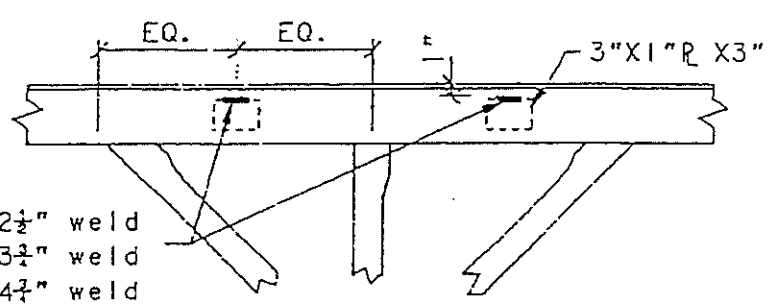

5" leg - $\frac{3}{8} \times 2\frac{1}{2}$ " weld
 Up to 6x6x $\frac{7}{8}$ - $\frac{3}{8} \times 3\frac{1}{2}$ " weld
 6x6x1 - $\frac{3}{8} \times 4\frac{1}{2}$ " weld

Bar applies to 5" and larger chords.

51) PLUGS AND STITCHES

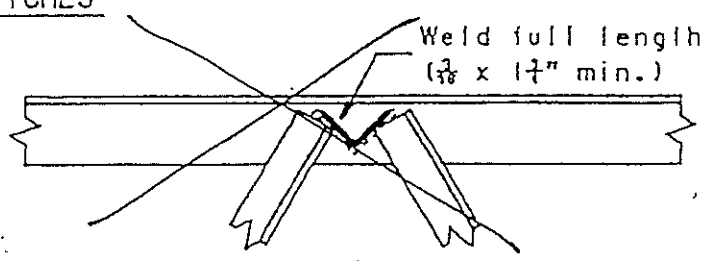

Use angle clip for $3\frac{1}{2}$ " and smaller chords.

4" leg - $\frac{3}{8} \times 1\frac{1}{2}$ "
 5" leg - $\frac{3}{8} \times 2\frac{1}{2}$ "
 Up to 6x6x $\frac{7}{8}$ - $\frac{3}{8} \times 3\frac{1}{2}$ "
 6x6x1 - $\frac{3}{8} \times 4\frac{1}{2}$ "

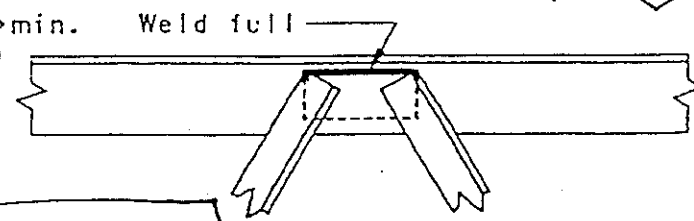

Use 3"X1"R X3" for 4" chords and 4"X1"R X4" for 5" and larger chords.

SPACER BAR
 CONFIGURATION REF.
 BY LAW ENG.

52) TOP CHORD PANEL POINT FOR LONGSPAN OR JOIST GIRDER

Vulcraft Spacer Bar Weld Re-Configuration

VULCRAFT

A Division of NUCOR Corporation

Post Office Box 169 Fort Payne, Alabama 35967 Telephone 205/845-2480

From Fax No.: 845-1090

Fax Number 404 872-5927

Date 3/27/96

Number of Pages Including Cover Sheet 1

Company LAW ENGR & ENVIRO. ATTN: TIMOTHY OZELL

From: MARK MILLER Please reply by Phone () Fax ()

Job Name OLYMPIC AQUATIC Job No. 27-4-0390

PER YOUR REQUEST TODAY AT THE
JOB SITE :

A $7/16$ " FILLET WELD X 3" LONG
WILL DEVELOP THE EQUIVALENT LOAD OF
A $3/16$ " FILLET WELD X $1\frac{3}{4}$ " LONG.

THANK YOU!

MARK MILLER

CC: JOEL BARNES, SMI-OWEN

803 251 7637

Vulcraft Spacer Bar Calculations

Vulcraft

A Division of NUCOR Corporation
P.O. Box 169 * Fort Payne, AL 35967

Company :
Attention : Milton Bradford
Fax Number : (404) 817-6677
9666

Project Name : Olympic Aquatic
Project Number : 27-4-0390

Sender: Vulcraft * Fort Payne, AL
From : Randy G. Pell

Fax Numbers : (205) 845-2139 (Eng.) (205) 845-2823 (Sales)
Phone : (205) 845-2460

Number of pages (including cover sheet) : 5

Date : 03/26/96

Reply by FAX () PHONE ()

Comments

Shop orders for joists marked 3T1 and 3T2, showing member lengths.

The PRY BAR weld test is used to check the spacer bars for 2% of the chord force.
The bar is to be of a length to allow an inspector to apply the required force to the weld.
The maximum chord force in the above referenced project is 114.178 kips, 2% of this is 2.2836 kips.

FIGURE ONE

Schematic of Laboratory Spacer Bar Tensile Test
Truss Collapse - Georgia Tech Aquatic Center
Atlanta, Georgia
LAW Project Number: 50163-6-0144
April 5, 1996

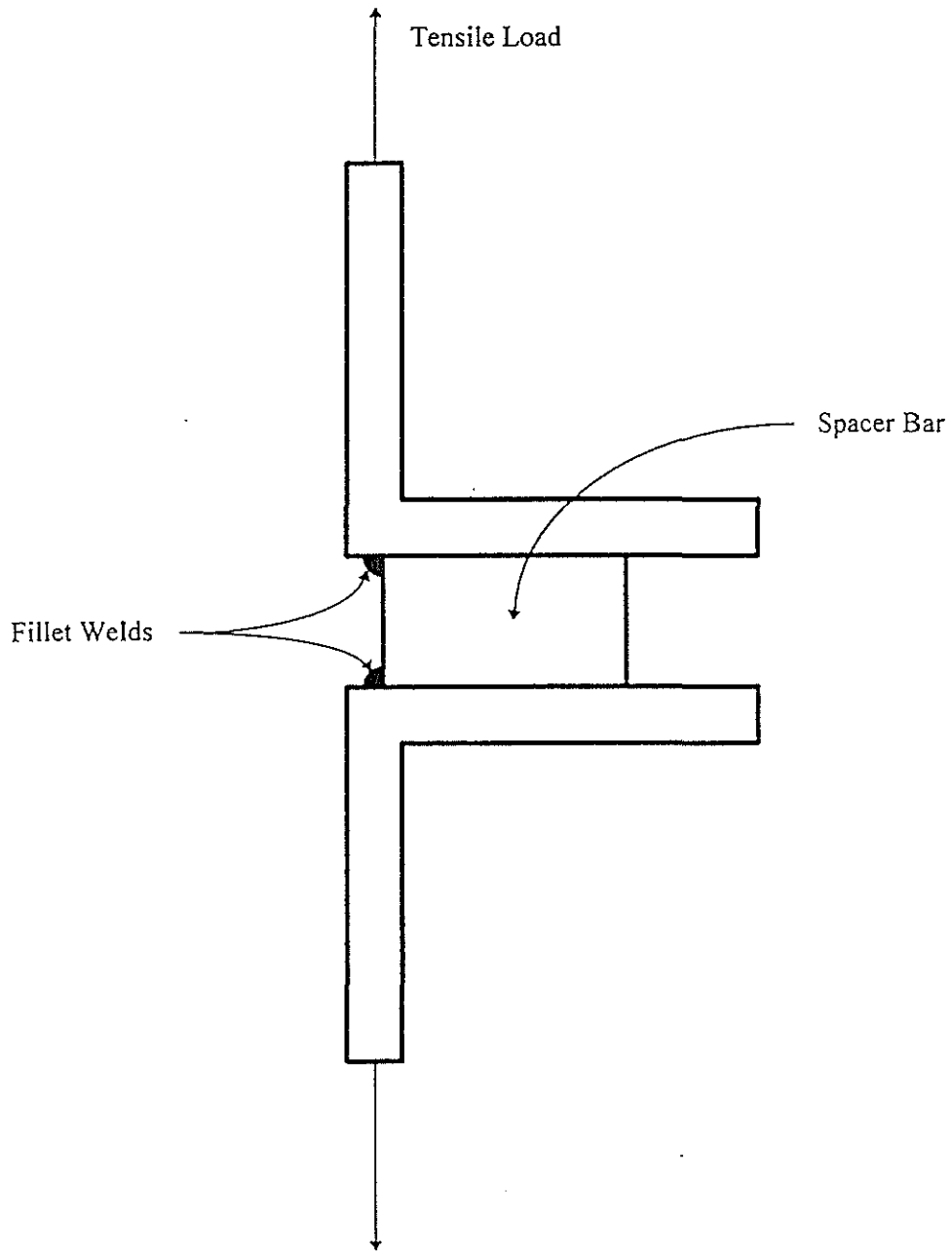

Section of Top/Bottom Chord

TABLE ONE

Results of Tensile Testing
 Truss Collapse - Georgia Tech Aquatic Center
 Atlanta, Georgia
 LAW Project Number: 50163-6-0144
 April 5, 1996

| Sample Number | Sample Identification | Width (in) | Thickness (in) | Area (in ²) | Yield Load (lbf) | Yield Strength (psi) | Ultimate Load (lbf) | Tensile Strength (psi) | Percent Elongation |
|---------------|-----------------------|------------|----------------|-------------------------|------------------|----------------------|---------------------|------------------------|--------------------|
| 1 | 3T1R #2 BC | 0.511 | 0.375 | 0.192 | 11,663 | 60,500 | 16,750 | 87,000 | 29 |
| 2 | 3T2L #2 TC | 0.520 | 0.382 | 0.199 | 11,475 | 57,500 | 16,860 | 84,500 | 32 |
| 3 | 3T2R #1 6R-W | 0.502 | 0.228 | 0.144 | 6,300 | 55,000 | 9,253 | 81,000 | 34 |
| 4 | 3T1L #2 8-W | 0.508 | 0.203 | 0.103 | 6,075 | 59,000 | 8,492 | 82,500 | 27 |
| 5 | 3T2R #1 8R-W | 0.510 | 0.220 | 0.112 | 6,413 | 57,500 | 9,274 | 83,000 | 27 |
| 6 | 3T2R #1 BC | 0.496 | 0.252 | 0.125 | 7,350 | 59,000 | 10,860 | 87,000 | 29 |

Notes: TC - indicates top chord sample
 BC - indicates bottom chord sample
 W - indicates web member sample

Specification Requirements:

| SPECIFICATION | YIELD STRENGTH, minimum, (psi) | TENSILE STRENGTH, minimum, (psi) | ELONGATION IN 2 INCHES, minimum, (%) |
|--------------------|--------------------------------|----------------------------------|--------------------------------------|
| ASTM A 529, Gr. 50 | 50,000 | 70,000 ¹ | 21 |
| ASTM A 572, Gr. 50 | 50,000 | 65,000 | 21 |

Note 1: Maximum allowable 100,000 psi.

LAW ENGINEERING

396 Plasters Ave. Atlanta, Ga. 30324

CONCRETE TEST REPORT

CLIENT: Gaston-Thacker/Whiting Turner

DATE: 03/21/96

PROJECT: Olympic Aquatic Center
Atlanta, Georgia

JOB NO: 5690740001

MIX ID: 2J160

LAB NO: 961118

SPECIFIED STRENGTH: 4,000 PSI

MIX DESC:

FIELD INFORMATION

FIELD TESTS

(ACTUAL)

(SPECIFIED)

DATE SAMPLED: 03/11/96 BY: PL

SLUMP, INCHES: 4 1/2

TIME BATCHED: 01:28 SAMPLED: 01:53

AIR, PERCENT: N.I.

BATCH PLANT: Allied Ready Mix

UNIT WEIGHT, PCF: N.I.

TRUCK/TICKET: 581537 DATE RECEIVED: 03/12/96 MIX/AIR TEMP, °F: 60/55

COMPRESSION TEST RESULTS

| CYLINDER NUMBER | DIAMETER (IN.) | AREA (SQ. IN.) | DATE TESTED | TEST AGE (DAYS) | MAX LOAD (LBS.) | COMP. STRENGTH (PSI) | FRACTURE TYPE |
|-----------------|----------------|----------------|-------------|-----------------|-----------------|----------------------|---------------|
| 1 | 6.01 | 28.37 | 03/18/96 | 7 | 87,060 | 3,070 | A |
| 2 | 6.01 | 28.37 | 04/08/96 | 28 | | | |
| 3 | 6.01 | 28.37 | 04/08/96 | 28 | | | |
| 4 | | | RESERVE | | | | |

UNLESS OTHERWISE INDICATED, TESTS WERE PERFORMED IN GENERAL ACCORDANCE WITH THE FOLLOWING ASTM TEST METHODS: C39, C138, C143, C173, C1064

* DENOTES CURED IN FIELD

<<< DENOTES LOW COMPRESSIVE STRENGTH

FRACTURE TYPE IS INDICATED BY LETTER: (A) CONE (B) CONE & SPLIT (C) CONE & SHEAR (D) SHEAR (E) COLUMNAR

POUR LOCATION: Footings B and E on line 11.

REMARKS: Sampled at 9 of 27 yards.

DISTRIBUTION:

Whiting-Turner ((1C,1D,1S))

Williams Brothers Concrete ((1C,1D,1S))

Thomas Concrete ((1C,1D,1S))

RESPECTFULLY SUBMITTED

Anthony D. Taylor

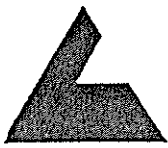

LAW ENGINEERING

396 Plasters Ave. Atlanta, Ga. 30324

CONCRETE TEST REPORT

CLIENT: Gaston-Thacker/Whiting Turner

DATE: 03/21/96

PROJECT: Olympic Aquatic Center
Atlanta, Georgia

JOB NO: 5690740001

MIX ID: 0

LAB NO: 10070

MIX DESC:

SPECIFIED STRENGTH: 4,000 PSI

FIELD INFORMATION

FIELD TESTS

(ACTUAL)

(SPECIFIED)

DATE SAMPLED: 03/12/96 BY: Contractor

SLUMP, INCHES: N.I.

TIME BATCHED: SAMPLED:

AIR, PERCENT: N.I.

BATCH PLANT: N.I.

UNIT WEIGHT, PCF: N.I.

TRUCK/TICKET: N.I.

DATE RECEIVED: 03/13/96 MIX/AIR TEMP, °F: N.I.

COMPRESSION TEST RESULTS

| CYLINDER NUMBER | DIAMETER (IN.) | AREA (SQ. IN.) | DATE TESTED | TEST AGE (DAYS) | MAX LOAD (LBS.) | COMP. STRENGTH (PSI) | FRACTURE TYPE |
|-----------------|----------------|----------------|-------------|-----------------|-----------------|----------------------|---------------|
| 1 | 6.01 | 28.37 | 03/19/96 | 7 | 103,220 | 3,640 | A |
| 2 | 6.01 | 28.37 | 04/09/96 | 28 | | | |
| 3 | 6.01 | 28.37 | 04/09/96 | 28 | | | |
| 4 | | | RESERVE | | | | |

UNLESS OTHERWISE INDICATED, TESTS WERE PERFORMED IN GENERAL ACCORDANCE WITH THE FOLLOWING ASTM TEST METHODS: C39, C138, C143, C173, C1084

* DENOTES CURED IN FIELD

<<< DENOTES LOW COMPRESSIVE STRENGTH

FRACTURE TYPE IS INDICATED BY LETTER: (A) CONE (B) CONE & SPLUT (C) CONE & SHEAR (D) SHEAR (E) COLUMNAR

POUR LOCATION:

REMARKS: Cylinders made and data submitted by contractor.

DISTRIBUTION:

Whiting-Turner ((1C,1D,1S))

Williams Brothers Concrete ((1C,1D,1S))

Thomas Concrete ((1C,1D,1S))

RESPECTFULLY SUBMITTED

Anthony D. Taylor

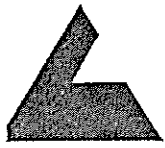

LAW ENGINEERING

396 Plasters Ave. Atlanta, Ga. 30324

CONCRETE TEST REPORT

CLIENT: Gaston-Thacker/Whiting Turner

DATE: 04/05/96

PROJECT: Olympic Aquatic Center
Atlanta, Georgia

JOB NO: 5690740001

MIX ID: 2J160

LAB NO: 961218

SPECIFIED STRENGTH: 4,000 PSI

MIX DESC:

FIELD INFORMATION

FIELD TESTS

(ACTUAL)

(SPECIFIED)

DATE SAMPLED: 03/15/96 BY: JH

SLUMP, INCHES: 3

TIME BATCHED: 03:09 SAMPLED: 03:30

AIR, PERCENT: N.I.

BATCH PLANT: Allied Ready Mix

UNIT WEIGHT, PCF: N.I.

TRUCK/TICKET: 581899 DATE RECEIVED: 03/16/96 MIX/AIR TEMP, °F: 68/71

COMPRESSION TEST RESULTS

| CYLINDER NUMBER | DIAMETER (IN.) | AREA (SQ. IN.) | DATE TESTED | TEST AGE (DAYS) | MAX LOAD (LBS.) | COMP. STRENGTH (PSI) | FRACTURE TYPE |
|-----------------|----------------|----------------|-------------|-----------------|-----------------|----------------------|---------------|
| 1 | 6.01 | 28.37 | 03/22/96 | 7 | 115,780 | 4,080 | A |
| 2 | 6.01 | 28.37 | 04/12/96 | 28 | | | |
| 3 | 6.01 | 28.37 | 04/12/96 | 28 | | | |
| 4 | | | RESERVE | | | | |

UNLESS OTHERWISE INDICATED, TESTS WERE PERFORMED IN GENERAL ACCORDANCE WITH THE FOLLOWING ASTM TEST METHODS: C39, C138, C143, C173, C1064

* DENOTES CURED IN FIELD

<<< DENOTES LOW COMPRESSIVE STRENGTH

FRACTURE TYPE IS INDICATED BY LETTER: (A) CONE (B) CONE & SPLIT (C) CONE & SHEAR (D) SHEAR (E) COLUMNAR

POUR LOCATION:

REMARKS: Sampled at 9 of 9 yards.

DISTRIBUTION:

Whiting-Turner ((1C,1D,1S))

Williams Brothers Concrete ((1C,1D,1S))

Thomas Concrete ((1C,1D,1S))

RESPECTFULLY SUBMITTED

Anthony D. Taylor



LAW

ENGINEERING AND ENVIRONMENTAL SERVICES

March 21, 1996

Mr. Kieth Douglas - Regional Manager
The Whiting-Turner Contracting Company
2300 Windy Ridge Parkway
Suite 155-G
Atlanta, Georgia 30339

Subject: Proposal for Materials Testing and Evaluation
Georgia Tech. Aquatic Center Truss Collapse
Atlanta, Georgia
LAW Proposal No. 563.96018

Dear Mr. Douglas:

Law Engineering and Environmental Services, Inc. (LAW) is pleased to submit this proposal to provide materials testing and evaluation services regarding the recent truss collapse. Our services were requested during an on-site meeting on March 20, 1996. The purpose of our work will be to perform the tasks outlined in the "Long-Span Joist Collapse Investigation" (Updated 03/20/96) prepared by Gaston-Thacker/Whiting-Turner.

SCOPE OF SERVICES

We plan to perform the following:

1. Provide engineers and technicians to inspect the steel members and welds on the joists and columns that have collapsed as described in the outlined tasks. The purpose of this evaluation will be to verify the member and weld sizes of the collapsed joists and columns comply with the drawings provided to us.
2. Selected portions of the top chord, bottom chord and web members of the failed joists will be marked for cutting by Helmark. LAW will return the samples to our laboratory to machine and test standard tensile specimens in accordance with ASTM specifications.
3. Assess the status of cylinders obtained during concrete placement for foundations related to the collapse. If cylinders were not obtained, the top surface of the footings will be evaluated for damage and we will provide recommendations on whether or not to obtain core samples for testing. If needed, we will obtain and test the core samples.
4. We will review our field reports regarding inspection of reinforcing bar placement within the associated footings prior to concrete placement.

LAW ENGINEERING, INC.

396 PLASTERS AVENUE, N.E. • ATLANTA, GA 30324
(404) 873-4761 • FAX (404) 881-0508

ONE OF THE LAW COMPANIES ©

The Whiting-Turner Contracting Company

March 21, 1996

Page 2

5. We will attend meetings as requested to provide progress updates. At this stage, we intend to provide written reports only as directed by Mr. Douglas.

The proposed scope of services is based on the above background information and our experience with similar projects. During our work, we understand that it may become necessary to modify this scope of services on a day-to-day basis.

ESTIMATED FEE

At this stage, we estimate a fee for this evaluation in the range of \$7,500 to \$11,000. The actual cost of our services will be based upon the time spent, the number and types of tests performed and the equipment used. The unit rates that will be used are presented in the attached Schedule of Fees. We will invoice you each month for the amount of work completed through the end of the invoicing period. Payment is due upon receipt of each invoice.

SCHEDULE

We began the field evaluation today based on your verbal authorization to proceed. Preliminary results of the tensile testing should be available by March 26, 1996. The schedule of the remaining tasks will vary depending on the timing of providing the shop drawings for the joists.

AUTHORIZATION

To formally authorize the proposed scope of services, please complete and return one copy of the attached Proposal Acceptance Sheet. Please note that the attached Terms and Conditions form a part of this proposal and any agreement or contract entered into as a result of this proposal, including purchase orders.

We look forward to serving as your materials engineering consultant on this project. If you have any questions concerning this proposal, please contact us.

Sincerely,

LAW ENGINEERING AND ENVIRONMENTAL SERVICES, INC.

Timothy A. Ozell, P.E.
Principal Engineer

James F. Lane
Materials Engineer

Attachments: Proposal Acceptance Sheet/Terms and Conditions
Schedule of Fees



LAW

ENGINEERING AND ENVIRONMENTAL SERVICES

June 12, 1996

Mr. Andy Francolini, Operations Manager
The Whiting-Turner Contracting Company
2300 Windy Ridge Parkway
Suite 155-G
Atlanta, Georgia 30339

Subject: Addendum to Report of Materials Testing and Evaluation
Georgia Tech. Aquatic Center Truss Collapse
88 SLH 210 Long Span Joists, Marks 3T1 and 3T2
Atlanta, Georgia
LAW Project No. 50163-6-0144

Dear Mr. Francolini:

We recently provided a report of materials testing and evaluation services related to the truss collapse at the subject project (Please refer to our *Report of Materials Testing and Evaluation* dated April 8, 1996). Since issuing our report, we were contacted by Mr. Mike Marshall of OSHA to discuss our report. During the discussion, Mr. Marshall requested a list of the welds on the trusses that we noted were fractured during our visual inspection.

The attached table lists the welds that were fractured or broken at the time of our inspection. At the time of our inspection, we did not attempt to distinguish between welds that failed due to the collapse and welds that may have failed causing the collapse. The location descriptions used were obtained from the Vulcraft design drawings of each truss.

If you have any other questions concerning this project, please contact us.

Sincerely,

LAW ENGINEERING AND ENVIRONMENTAL SERVICES, INC.

Timothy A. Ozell, P.E.
Principal Engineer

Darron V. Edens
Staff Engineer

Attachments: Table One

LAW ENGINEERING, INC.

396 PLASTERS AVENUE, N.E. • ATLANTA, GA 30324
(404) 873-4761 • FAX (404) 881-0506

TABLE ONE

Weld Failures on T1 & T2 Truss Members
 Truss Collapse - Georgia Tech. Aquatic Center
 Atlanta, Georgia
 LAW Project Number: 50163-6-0144
 June 12, 1996

SPACER WELDS ON THE T2 JOIST

| LOCATION | |
|----------------------|--------------------|
| Top Chord | Bottom Chord |
| V4 Far Side | |
| 9 @ 10 Both Sides | |
| | V8 Both Sides |
| | V9 Both Sides |
| 15 @ 15R Both Sides | |
| 12R @ 11R Both Sides | |
| | V11 Both Sides |
| 8R @ 7R Both Sides | |
| V12 Both Sides | V12 Both Sides |
| 6R @ 5R Both Sides | |
| V13 Both Sides | |
| 4R @ 3R Both Sides | 4R @ 3R Both Sides |

SPACER WELDS ON THE T1 JOIST

| LOCATION | |
|---------------------|----------------|
| Top Chord | Bottom Chord |
| V9 Far Side | V8 Both Sides |
| | V9 Both Sides |
| | V10 Both Sides |
| 15 @ 15R Both Sides | |
| 9R @ 10R Both Sides | |
| V11 Both Sides | V11 Both Sides |
| V12 Both Sides | |
| 5R @ 6R Both Sides | |
| V13 Both Sides | |
| 3R @ 4R Both Sides | |

WEB MEMBERS WELDS ON JOIST T2

| LOCATION | |
|---------------|----------------|
| Top Chord | Bottom Chord |
| | 15R Both Sides |
| | 6R Far Side |
| 5R Both Sides | |
| | V13 Both Sides |
| 3R Both Sides | |
| | 2R Both Sides |

WEB MEMBERS WELDS ON JOIST T1

| LOCATION | |
|----------------|----------------|
| Top Chord | Bottom Chord |
| | 10 Both Sides |
| 11R Both Sides | |
| | 8R Both Sides |
| 7R Both Sides | |
| | V13 Both Sides |

APPENDIX D

SJI Letter dated June 7, 1996

STEEL JOIST INSTITUTE

1205 48th AVENUE NORTH, SUITE A, MYRTLE BEACH, S.C. 29577 (803) 449-0487 FAX (803) 449-1343

June 7, 1996

Mr. Mohammad Ayub
Chief, Office of Engineering Services
Directorate of Construction
U.S. Department of Labor
Occupational Safety and Health Administration
Washington, DC 20210

Dear Mr. Ayub:

Thank you for your letter of May 16, 1996 regarding anchoring for erection bridging for LH and DLH Series Steel Joists. As a matter of general clarification, LH and DLH Series Steel Joists are standardized Steel Joist Institute products ranging in depth from 18 inches through 72 inches with a maximum span limitation of 144 feet.

The Steel Joist Institute offers the following comments regarding the four issues contained in your letter of May 16th:

1. Bolted diagonal erection bridging as required by Steel Joist Institute specifications must be anchored prior to releasing the hoisting cable(s).
2. Yes, as stated above.
3. Joist span, depth, self weight, design properties and job conditions have a pronounced effect on the stability of each individual joist. Therefore, lateral stability must be provided for steel joists during the erection process by anchoring of the lines of bolted diagonal erection. This anchoring must be established prior to releasing the hoisting cables.
4. The phrase "any load" contained in the second paragraph of Section 105(C) is different than references to "Construction Loads." "Construction load or loads" as used in other sections of the Steel Joist Institute Standard Specifications would not include the self weight of the LH or DLH joists. I am unclear as to the meaning of the words "dead load of the structure." If by these words you mean the self weight of the joists, this load is not included in the words "construction load or loads." The term "any load" used in the Steel Joist Institute Standard Specifications, and specifically Section 105(C), is all inclusive and would include any dead load.

Page 2

The Steel Joist Institute's Technical Digest #9, "Handling and Erection of Steel Joists and Joist Girders" provides guidance for the proper erection of steel joists. Enclosed is a copy of this digest for your review. I have taken the liberty of high-lighting particular paragraphs on pages 25 and 34 through 37 which may be germane to your inquiry.

We trust the above information addresses your concerns.

Cordially,

R. Donald Murphy
Managing Director

cdp

Enclosure

May 16, 1996

FILE COPY

Mr. R. Donald Murphy
Managing Director
Steel Joist Institute
1205, 48 th Avenue North Suite A
Myrtle Beach, SC 29577-5424

Subject: Erection Stability and Handling Section 105. (SJI Fortieth Edition)

Dear Mr. Murphy:

We request an official written interpretation of the above section relating to the anchorage of the bridging lines during erection of steel joists. If the spans of the LH and DLH joists exceed the erection stability spans as indicated in the blue and gray shaded areas of the published SJI load tables,

1. At what stage of erection, should the bolted diagonal bridging lines as required in SJI Section 105, 2 (b,c) be anchored ?
2. Should the required bridging lines be anchored prior to the release of the hoisting cables ?
3. After the release of the hoisting cables, are such LH and DLH joists capable of supporting their own dead load with the required bolted diagonal bridging lines in place without anchorage of the bridging lines or is the anchoring requirement stipulated to provide an adequate degree of safety for the erected joists ?
4. Is the phrase " any load " contained in the second paragraph of the Section 105 C different than other references to " Construction loads", i.e., "Construction load" would not include the dead load of the structure, while "any load" would include the dead load ?

If you need any clarifications or have any questions, please do not hesitate to call us at 202-219-8429. We would highly appreciate an early response from you. Thank you for your assistance.

(Mohammad Ayub)
Chief, Office of Engineering Services
Directorate of Construction
202-219-8429